

# EMOSAFE EN-95

Datasheet

## Network Isolator for Industrial and Railway Applications



## 1 FEATURES AND ADVANTAGES

- Heavy duty housing (IP65)
- M12 x-coded connectors (IEC 61076-2-109)
- Ready for the use in railways according to DIN EN 50155 and IEC 61373
- Gigabit Ethernet (Class D and Cat 5e)
- Dielectric strength of 4.0 kV AC or 5.6 kV DC
- ESD protection: Suppression of transient over voltages on the signal lines
- Suitable for devices with a supply voltage of up to 250 V AC
- UL94-Flame category V0
- RoHS compliant
- DIN rail adapter available as accessory

## 2 GENERAL DESCRIPTION

EMOSAFE EN-95 network isolators interrupt the electrically conductive connection (wires and shield) between devices that are connected to each other via copper-guided Ethernet cabling. They prevent equipotential bonding currents and protect connected devices and their users from transient over voltages that have been directly or inductively coupled into the network cable because of installation errors, lightning, switching operations, or electrostatic discharges.

The network isolator EN-95 provides a safe operation of electronic equipment on railway vehicles regarding the network connection. The EN-95 fulfils all design requirements of DIN EN 50155 and IEC 61373.

The EN-95 is equipped with a TVS diode circuit that effectively limits the differential interference signal level on each wire pair. Differential voltage peaks can be caused by malfunctions of connected devices or by electrostatic discharges during the plugging process.

The network isolator EN-95 passes high-frequency alternating signals according to the principle of electromagnetic induction in the frequency range used for data transmission. Because of this transmission principle, the EN-95 does not require any power supply. Also, no driver installation is required.

### 3 APPLICATIONS

---

- **Potential differences (Industrial plants, building and railway systems)**  
Prevention of equipotential bonding currents in computer systems that are galvanically connected to each other via Ethernet cabling over greater distances.
- **User protection**  
Galvanic isolation of the Ethernet interfaces of electrical devices or systems where users must be protected against dangerous leakage currents in accordance with standards.
- **Equipment protection**  
Applications, in which valuable devices or those requiring special protection need to be protected against ripple, mains hum, and surge voltages from the network periphery.
- **Measurement Equipment**  
Electrical measuring and monitoring equipment, which needs to be protected against external voltages and interference voltages arising from the Ethernet periphery.

## 4 DRAWINGS

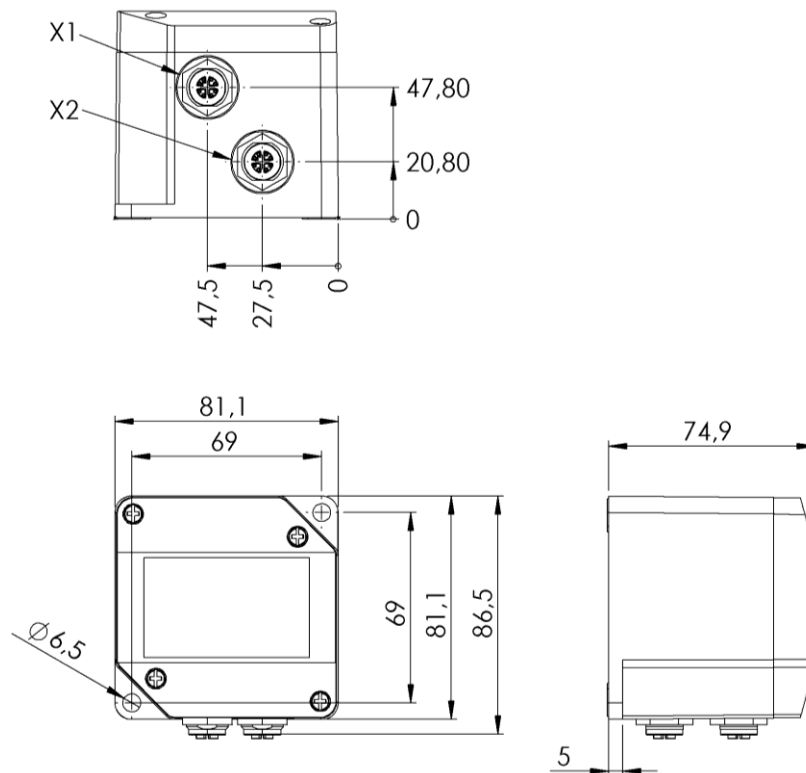

Figure 1 EN-95 (all dimensions in mm with comma as decimal separator)

## 5 MOUNTING AND SAFETY INSTRUCTIONS

- Tightening torque for the mounting screws: 2 Nm  
 Tightening torque of the M12 connectors: 0.6 to 1 Nm

### 5.1 INSTALLATION OF DEVICES

During installation, it may be necessary to ensure that the clearance and creepage distances required by DIN EN-50155 are adhered to. The insulation effect of the network insulator must not be impaired by adjacent conductive components.

### 5.2 HOUSING AND PLUG ENVIRONMENT

The metal conductive parts of the M12 sockets and the connected plugs are freely accessible to the user and offer no protection. If the risk management process of the organisation responsible shows unacceptable risks in the event that operators could touch the enclosure or exposed conductive parts, the network isolator and exposed conductive surfaces can be surrounded with a suitable enclosure.

### 5.3 CABLE SHIELD

The EMOSAFE EN-95 has an additional circuit between the shield connections of the M12 sockets (Figure 2). The resistor is used for the high-impedance and safe discharge of static charges. The low capacitance of the safety capacitor improves the EMC properties for high frequencies.

## 5.4 POWER OVER ETHERNET

Type EN-95 network isolators can be used in a PoE network without restriction. However, PoE terminals cannot be supplied with power after galvanic isolation.

# 6 SPECIFICATIONS

## 6.1 GENERAL

Category	Standards or Test Criteria	Properties
Designation		EMOSAFE EN-95
Part number		A10302
Construction		Standalone
Housing Color		Black
Housing Material		Glass fiber reinforced polyester, with graphite additive
PCB		FR4 (EN 45545-2) with an anti-corrosion coating
Interface	X1 / X2	M12-Jack, X-coded, female, strait (IEC 61076-2-109)
Weight		347 g
Protection Rating	With plugged Connectors	IP65
UL 94 Flame Classifications		V0
Approval for rolling stock equipment	EN 50155 & IEC 61373	✓
Mating Cycles	M12X-Jack into M12X-connector	> 1000
MTTF (25°C)	SN 29500 Standard, Temperature 25°C, Working Cycles 100 % (7 days, 24 hr)	2400 years

## 6.2 ETHERNET PERFORMANCE

Category	Standards or Test Criteria	Properties
Supported Ethernet speeds	IEEE 802.3	100BASE-TX up to 100 MHz* 1000BASE-T up to 100 MHz* 2.5GBASE-T up to 100 MHz*
	ISO/IEC 11801	Class D (CH & PL) up to 100 MHz*
	TIA/EIA-568	Cat 5e (CH & PL) up to 100 MHz*

\* Maximum bandwidth frequency

If an EN-95 is part of a cabling path that is to meet the requirements for a Class D or Cat 5e channel, the channel must provide a performance reserve without a network isolator in use. The following distances to

the Class D or Cat 5e limit curves must be observed when measuring the cabling section without a network isolator:

- Insertion loss: 1.5 dB
- Return loss: 4.0 dB
- NEXT: 4.0 dB

### 6.3 ELECTRICAL

Category	Standards or Test Criteria	Properties
AC Dielectric Strength	@ 50 Hz, for 60 s	4.0 kV
DC Dielectric Strength	for 60 s	5.6 kV
Coupling Capacitance / Channel		37.5 pF ±25%
Total Coupling Capacitance		150 pF ±25%
TVS diode circuitry	suppression of transient over voltages on signal lines	✓

### 6.4 OPERATING CONDITIONS AND AREA OF APPLICATION

Category	Standards or Test Criteria	Properties
Overvoltage Category	IEC 60664-1	III
Maximum Working Voltage*	Maximum mains voltage of the connected devices, in accordance with DIN EN 50155	250 V AC 300 V DC
Temperature		Minimum: -40°C
		Maximum: +70°C
Air Humidity	Non-condensing	Minimum: 10%
		Maximum: 90%
Air Pressure		Minimum: 700 hPa
		Maximum: 1060 hPa
Altitude		Maximum: 3200 m

\* The Network Isolator can be permanently exposed to this voltage level.

## 6.5 ENVIRONMENTAL CONDITIONS: STORAGE AND TRANSPORTATION

Category	Standards or Test Criteria		Properties
Temperature		Minimum:	-40°C
		Maximum:	+85°C
Air Humidity	Non-condensing	Minimum:	10%
		Maximum:	95%
Air Pressure		Minimum:	500 hPa
		Maximum:	1060 hPa

## 6.6 CERTIFICATES

The versions of the cited standards and directives to which our products comply with can be found in our Declaration of Conformity on our website under "[Standard Conformity and Certificates](#)".

## 7 CIRCUIT DIAGRAM

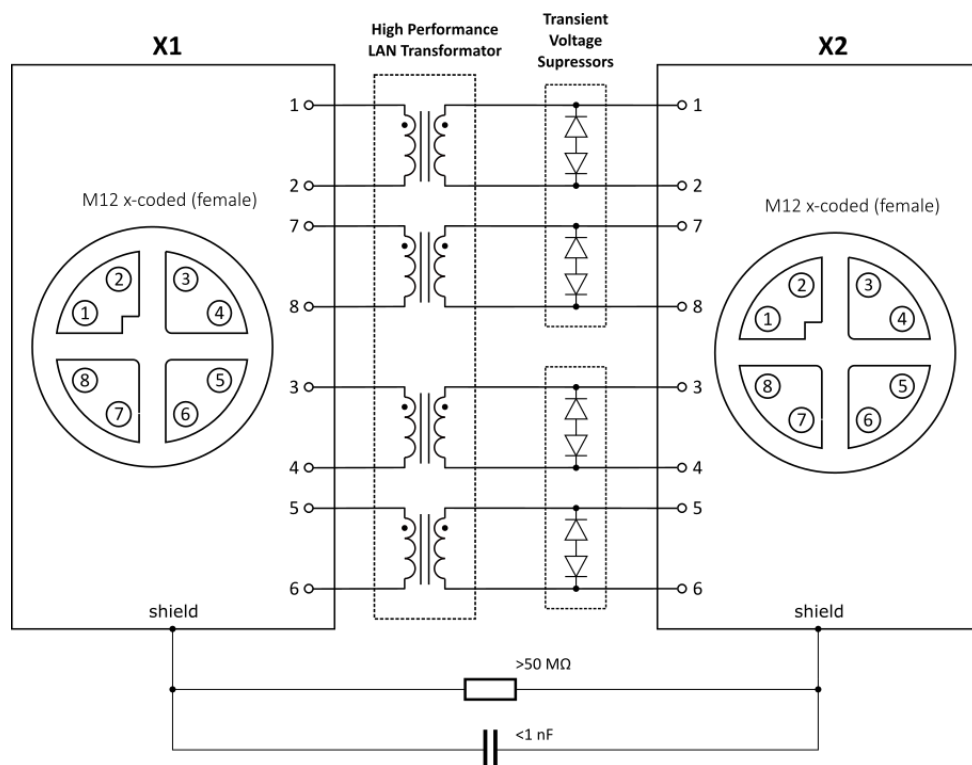

Figure 2 Circuit Diagram of the EN-95.



## 8 SCHEDULED MAINTENANCE

---

EMOSAFE network isolators are maintenance-free when used as intended.

## 9 PRODUCT MARKINGS

---

	<p>Through this mark, the conformity of the product with all applicable EU Directives is confirmed.</p>
	<p>The product may not be disposed of in domestic rubbish.</p>
	<p>This product meets the requirements of EU Directive concerning the limitation of the use of certain hazardous substances in electric and electronic equipment.</p>

## 10 ACCESSORIES

---

A DIN rail adapter is available for the EMOSAFE EN-95 network isolator.

## 11 QUALITY

---

EMO Systems GmbH maintains a certified quality management system for development and production in accordance with ISO 9001 and ISO 13485. Every network isolator is subjected to extensive quality control before delivery. Among other things, it is checked whether the achieved values for leakage current, dielectric strength, insertion loss, return loss and near crosstalk (NEXT) correspond to the specifications.

You will also find a declaration of conformity on our website confirming that the EMOSAFE network isolators comply with the requirements of the Low Voltage Directive (2014/35/EU), the Electromagnetic Compatibility Directive (2014/30/EU) and the Restriction of Use Directive hazardous substances in electrical and electronic equipment (2011/65/EU, RoHS).

## 12 ENVIRONMENTAL PROTECTION INFORMATION

---

This device contains electronic components.

It must be returned to the manufacturer for disposal after use.

## 13 CONTACT AND SUPPORT

---

You can find the current contact details on our website: <https://emosystems.de/en/contact/>

Or you can reach us by email at the following address: [support@emosystems.de](mailto:support@emosystems.de)

## 14 LEGAL NOTICE

---

The information in this data sheet has been compiled to the best of our knowledge and with all care. However, we cannot guarantee that they are complete and error-free.

The user is responsible and liable for the correct use of this product. Neither EMO Systems GmbH nor EMO Systems Inc. assume liability.

This data sheet is subject to change without prior notice.