

EMOSAFE EN-1005+

Product Datasheet

High Performance Network Isolator



1 FEATURES AND ADVANTAGES

- High performance Gigabit Ethernet
- 5.0 kV AC dielectric strength
- 8.5 kV DC dielectric strength
- Conforms to IEC 60601-1
- UL Recognized Component
- ISO 11801 Class D Ethernet performance is achievable
- Extremely low insertion losses; thereby total cable lengths of 100 metres are achievable
- ESD-Protection: Transient voltage suppression on all signal lines
- Suitable for devices with supply voltages up to 400 V AC
- RoHS compliant
- 100% inspection of Ethernet performance and dielectric strength by our Quality Control
- Socket and DIN rail adapter accessories

2 GENERAL DESCRIPTION

EMOSAFE EN-1005+ Network Isolators disconnect every electrically conducting connection (specifically the data and shield conductors) between devices connected together via a copper-based Ethernet network. The Network Isolators prevent current flow resulting from differences in electrical potentials, and also protect connected devices and their users from stray external voltages and power surges which may be directly or inductively coupled onto the network lines by causes such as installation errors, lightning, switching operations, and electrostatic discharge.

Connected to a medical electrical (ME) product, the EMOSAFE EN-1005+ Network Isolator facilitates the safe Ethernet connection of this ME product within the patient environment. The EN-1005+ satisfies all

construction requirements of IEC 60601-1 (3rd Edition) in the formation of two means of patient protection (MOPP) within the network interface, thereby practically eliminating the risk of electrical shocks arising from such stray external voltages at the network connection. With its UL approval, the EN-1005⁺ is also suitable for devices destined for export to the North American markets.

The EMOSAFE EN-1005⁺ is a compact, high-performance Gigabit-capable network isolator, characterised by its excellent Ethernet performance and a very high dielectric withstand voltage. The optional accessories Z-6W and Z-6R provide a range of possibilities for mounting on flat surfaces and DIN rails.

The EN-1005⁺ is equipped with transient voltage suppression (TVS) diode circuitry. While conventional network isolators can only block voltage spikes that occur simultaneously at all signal lines (arising, for example, from potential voltage differences), potentially dangerous or damaging differential voltages on individual signal lines are clipped by the TVS circuitry, preventing these voltages from reaching Ethernet devices, operators, and patients. Such differential voltage spikes can be caused, for example, by malfunctioning devices connected to the Ethernet, or also by electrostatic discharge events during the plugging processes.

Low-frequency signal components are strongly attenuated, so that connected devices may, for example, be protected against ground loops.

EMOSAFE Network Isolators transmit high-frequency signals through the principle of electromagnetic induction. Because of this, they do not require their own power supplies. There are no software drivers to be installed.

3 APPLICATIONS

3.1 PATIENT PROTECTION

Electrical separation of Ethernet interfaces of medical electrical (ME) devices and systems, where patients must be protected from dangerous leakage currents, in conformity with applicable standards.

3.2 EQUIPMENT PROTECTION

Applications, in which valuable devices or those requiring special protection need to be protected against ripple, mains hum, and surge voltages from the network periphery.

3.3 MEASUREMENT TECHNOLOGY

Electrical measuring and monitoring equipment, which needs to be protected against external voltages and interference voltages arising from the Ethernet periphery.

3.4 POTENTIAL DIFFERENCES (TECHNICAL BUILDING SYSTEMS)

Computer systems, which are electrically connected with each other over significant distances via Ethernet cabling, where current flows caused by potential differences must be prevented.

3.5 AUDIO

Audio applications, in which the transmission of low frequency alternating current voltages (mains hum) over the network connection is to be reduced to an imperceptible level.

4 DRAWINGS

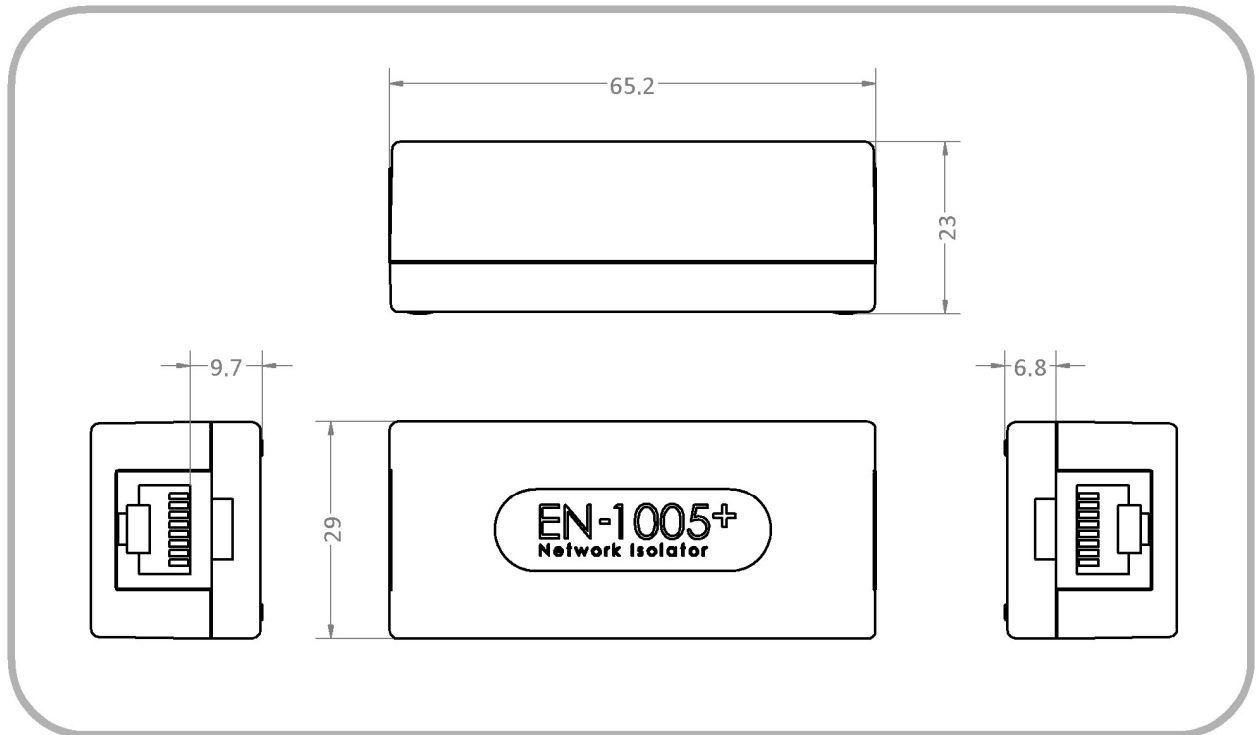

Figure 1. Physical dimensions of the EN-1005+. All dimensions in millimetres.

5 INSTALLATION INFORMATION

5.1 GENERAL

EN-1005+ Network Isolators are designed to be retrofitted to unprotected Ethernet network devices. It is important to ensure that the conductive parts of the incoming patch cable are kept distanced from all conductive parts of the end device. To ensure permanent protection, it is highly recommended that the Network Isolator is securely mounted in place. With the optional Z-6W socket (see section 12.1), the EMOSAFE EN-1005+ can be securely, yet detachably mounted to any surface, including electrically conductive surfaces, and still provide standard-compliant isolation protection.



Figure 2. EN-1005+ with accessory Z-6W mounted upon a metallic surface.

5.2 FREQUENCY RANGE

EN-1005+ Network Isolators are designed for data transmission in the frequency range of 300 kHz to 100 MHz. Lower frequencies are strongly attenuated. For this reason, it is generally not possible to transmit the signals from nurse call systems, telephone systems or analogue audio / video signals over a Network Isolator.

5.3 POWER OVER ETHERNET

The EN-1005+ Network Isolator can be used in a Power over Ethernet (PoE) network without restriction (however PoE devices downstream of the electrical isolation are not supplied with power).

5.4 EQUIPMENT INSTALLATION

When designing Network Isolators into equipment or devices, it is essential that the manufacturer observes the applicable creepage and clearance distances. Specifically, the creepage and clearance distances between exposed metal surfaces of Ethernet patch cables plugged into the Network Isolator, and the next-closest electrically conducting components of the equipment or device to be protected. These distances must be designed to comply with the relevant requirements and standards. If needs be, this next-closest electrically conducting component must be appropriately bonded to the protective earth connection.

5.5 CABLE SHIELD

EN-1005+ Network Isolators also disconnect the shield connections in Ethernet cabling. If the cable shield of the incoming data cable is to be connected with the room or equipment potential, such a connection must be carried out separately before the Network Isolator, effectively bypassing the Network Isolator.

5.6 PERFORMANCE RESERVE REQUIREMENTS UPON FIXED CABLING

EMOSAFE EN-1005+ Network Isolators can also be used to provide permanently installed Ethernet cabling with electrical isolation at the outlet termination. For an Ethernet cabling installation, including its termination of an EN-1005+ Network Isolator, to completely meet the requirements of a Channel according to ISO 11801 Class D or TIA/EIA 568 Cat.5e for Gigabit Ethernet, the cabling itself (without the Network Isolator) must provide a performance reserve. The following performance reserves to the Class D or Cat.5e limiting curves must be met without a Network Isolator:

NEXT:	4.0 dB
Return Loss:	4.0 dB
Insertion Loss:	1.5 dB

If a cabling installation which satisfies this requirement is equipped with an EN-1005+ Network Isolator, the installation as a whole will meet the requirements stated above. As required, this can then be verified using a cable certification device. For this, see also [7.1 Function and Compliance Tests](#).

6 SAFETY NOTICE

6.1 ASSEMBLY

During assembly, attention should be paid (when applicable) to ensure that the clearance and creepage distances required by IEC 60601-1 are met. The isolating effect of the Network Isolator must not be compromised by neighbouring conductive components. If, for example, the installation of the Network Isolator is to be within a metal plate, this plate must be connected to the ground potential (protective earth).

As a matter of principle, Network Isolators should be mounted as close as possible to the equipment requiring protection.

6.2 ENCLOSURE AND CONNECTION AREAS

The Network Isolator provides excellent protection between input and output, however the plastic enclosure provides only basic isolation. Furthermore, the connected plugs and the areas around the receptacles may have metal surfaces accessible to human contact, and therefore provide no protection. If the risk management process of the responsible organisation (i.e. manufacturer or operator, as defined in IEC 60601-1) reveals unacceptable risks that operators or patients can touch the housing or exposed conducting parts while the Ethernet cabling is connected to a potentially dangerous voltage, the Network Isolator and the exposed conducting surfaces must be surrounded with an appropriate enclosure to ensure the required means of protection for the application.

6.3 DAMAGE AND CONTAMINATION

Damaged Network Isolators, and Network Isolators which are contaminated by dust or liquids, are to be replaced.

7 FUNCTION AND SAFETY TESTS

7.1 FUNCTION AND COMPLIANCE TESTS

A cable run equipped with an EN-1005⁺ Network Isolator can be checked with regard to its transmission characteristics using cable certification devices which are suitable for testing an electrically isolated cable run. To be able to conduct such an inspection, the test equipment must be configured in an AC wire-map mode. With the installed Network Isolator, the entire cable run can be approved according to EIA/TIA-568 Cat.5e or ISO 11801 Class D. Testing of the cable shielding and the individual conductor resistance is not possible in such an AC test mode.

7.2 SAFETY INSPECTIONS

Regular safety inspections and post-repair inspections are not prescribed for Network Isolators in medical use, as Network Isolators themselves are not classified as medical electrical (ME) devices. However, together with a connected ME device, Network Isolators form part of an ME system, which altogether may be subject to statutory inspection. The test interval, as well as the requirements to be met for both regular safety inspections and post-repair inspections will be specified by the responsible organisation (e.g. manufacturer or operator as defined by the regulations), and based upon the applicable standards for the entire ME system.

To simplify implementation, the individual components of the ME system (in this case, the Network Isolator) can be tested separately. Here as well, the responsible organisation specifies the test parameters, test interval and in the event of a failed test, the consequences. Depending on the requirement profile, the test can include one or more of the following individual tests:

7.2.1 VISUAL INSPECTION

Check for evidence of external damage and ingress of substances; dust or liquids for example.

7.2.2 LEAKAGE CURRENT TEST

It is to be checked if the measured leakage current is still within the prescribed limits. For this purpose, test equipment which can perform equipment leakage current measurements in accordance with IEC 62353 may be used. To perform a leakage current test, all conductors on the input side must be short-circuited together, and all the conductors on the output side must also be short-circuited together. The AC test voltage specified by the responsible organisation is then applied across these two connections. Input and output sides are interchangeable. The expected current flow can be found in section [8 Specifications](#).

7.2.3 HIPOT TEST

To ensure that the device under test is not damaged, it is recommended that a DC voltage source is used in place of the AC voltage source, and that the DC voltage is 1½ times that of the required AC voltage. The test setup is essentially the same as that of the Leakage Current Test above. The expected dielectric strength can be found in section [8 Specifications](#).

7.2.4 FUNCTIONAL TEST

After conducting the tests above, and reconnecting the Network Isolator into the Ethernet network, it is recommended to check whether the signal transmission is still performing correctly. Such a functional test can be performed, for example, with a suitable Ethernet cable certification device. See also section [7.1 Function and Compliance Tests](#).

8 SPECIFICATIONS

8.1 GENERAL

Category	Standards or Test Criteria	Property
Designation		EMOSAFE EN-1005 ⁺
Article number		A10065
Housing colour		Grey
Housing Material		Plastic
Construction		Self-Enclosed
Input Interface		RJ45 Jack, straight
Output Interface		RJ45 Jack, straight
Weight		approximately 30 g
Protection rating	EN 60529	IP40
Mating cycles: Correct:	RJ45 plug in RJ45 socket	> 1000 cycles
Mismatched:	with RJ11 / RJ12 / RJ25	maximum of 100 cycles
Mean Time To Failure (MTTF)	SN 29500 Standard Temperature: 25°C Duty cycle: 100% (24 hours, 7 days)	3,230 years
	SN 29500 Standard Temperature: 40°C Duty cycle: 100% (24 hours, 7 days)	3,060 years

8.2 ETHERNET PERFORMANCE

Category	Standards or Test Criteria	Property
Transmission Speeds and Supported Network Protocols	10 Mbit/s, 10Base-T (IEEE802.3 Cl.14)	✓
	100 Mbit/s, 100Base-Tx (IEEE802.3 Cl.25)	✓
	1000 Mbit/s, 1000Base-T (IEEE802.3 Cl.40)	✓
Performance Category	ISO 11801, Channel (CH)	Class D
Insertion Loss (absolute) at 100 MHz	Typical:	0.7 dB
	Maximum:	1.0 dB
Return Loss (absolute) at 100 MHz	Typical:	20.0 dB
	Minimum:	16.0 dB

8.3 ELECTRICAL

Category	Standards or Test Criteria		Property
AC Dielectric Strength	at 50 Hz, for 60 seconds		5.0 kV
DC Dielectric Strength	for 60 seconds		8.5 kV
Reinforced Isolation	IEC 60601-1		✓
Coupling Capacitance per Channel			37.5 pF ±25%
Total Coupling Capacitance			150 pF ±25%
Total Leakage Current	275 V AC at 50 Hz	Typical:	12.0 µA
		Maximum:	16.0 µA
TVS Diode Circuitry	Suppression of transients on the signal lines		✓

8.4 OPERATING CONDITIONS AND AREA OF APPLICATION

Category	Standards or Test Criteria		Property
Pollution Degree	IEC 61010		2 *
Overvoltage Category	IEC 60664-1		III
Maximum Working Voltage †	Maximum mains voltage of the connected devices, in accordance with IEC 60601-1		400 V AC 450 V DC
Temperature		Minimum:	-10°C
		Maximum:	+70°C
Air Humidity	Non-condensing	Minimum:	10%
		Maximum:	90%
Air Pressure		Minimum:	700 hPa
		Maximum:	1,060 hPa

* Normally only nonconductive pollution occurs. Temporary conductivity caused by condensation is to be expected.

† The Network Isolator can be permanently exposed to this voltage level.

8.5 ENVIRONMENTAL CONDITIONS: STORAGE AND TRANSPORTATION

Category	Standards or Test Criteria		Property
Temperature		Minimum:	-40°C
		Maximum:	+70°C
Air Humidity	Non-condensing	Minimum:	10%
		Maximum:	90%
Air Pressure		Minimum:	500 hPa
		Maximum:	1,060 hPa

8.6 CERTIFICATES

Category	Property
UL Recognized Component	✓
UL File No.	E362969
IEC 60601-1	✓
IEC 60601-1-2	✓
ANSI/AAMI ES 60601-1	✓
CAN/CSA-C22.2 No. 60601-1	✓
Low Voltage Directive	✓
EMC Directive	✓
RoHS Directive	✓
Lead-free	✓

The versions of the cited standards and directives to which our products comply with can be found in our Declaration of Conformity and our UL certificate on our website under "[Standard Conformity and Certificates](#)".

8.7 ISOLATION DIAGRAMS

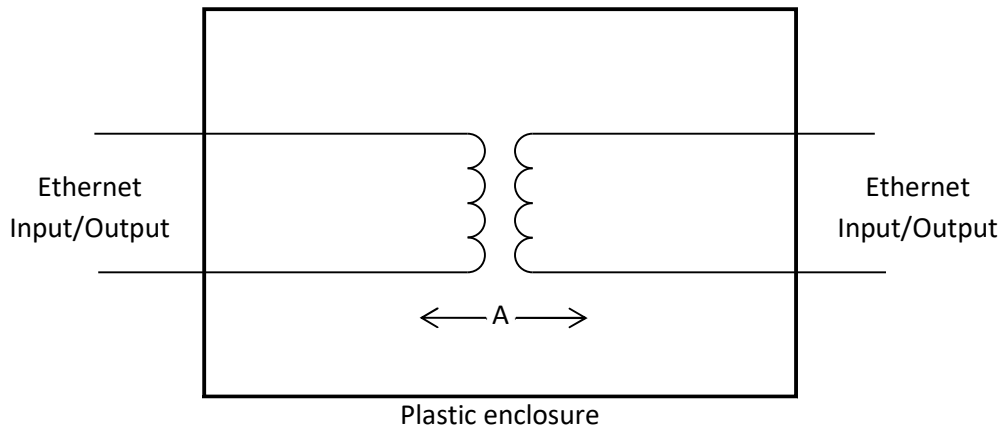

Figure 3. Isolation diagram for EN-1005+.

Area	Number and type of Means of Protection	Material Group (from CTI)	Maximum Operating Voltage		Required creepage distance (mm)	Required clearance distance (mm)	Measured creepage distance (mm)	Measured clearance distance (mm)
			V AC	V _{peak}				
A	2 MOPP *	IIIb †	400	565	12.0	7.0	12.4	12.4

For additional information see also chapter 6.2 Enclosure and Connection Areas.

* MOPP = Means of Patient Protection

† Materials in the Material Group IIIb have a Comparative Tracking Index (CTI) value between 100 and 175.

8.8 FREQUENCY RESPONSE

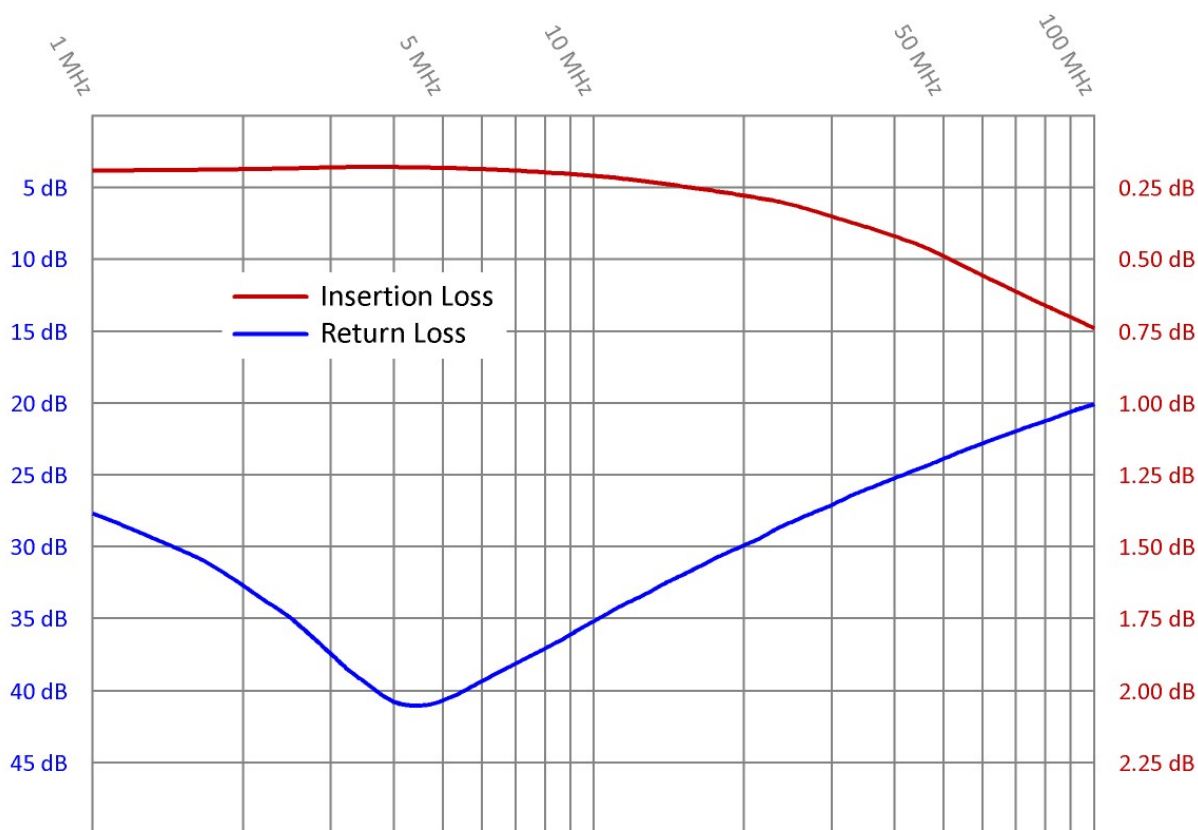

Figure 4. Typical frequency response for EN-1005*.



9 SCHEMATIC DIAGRAM

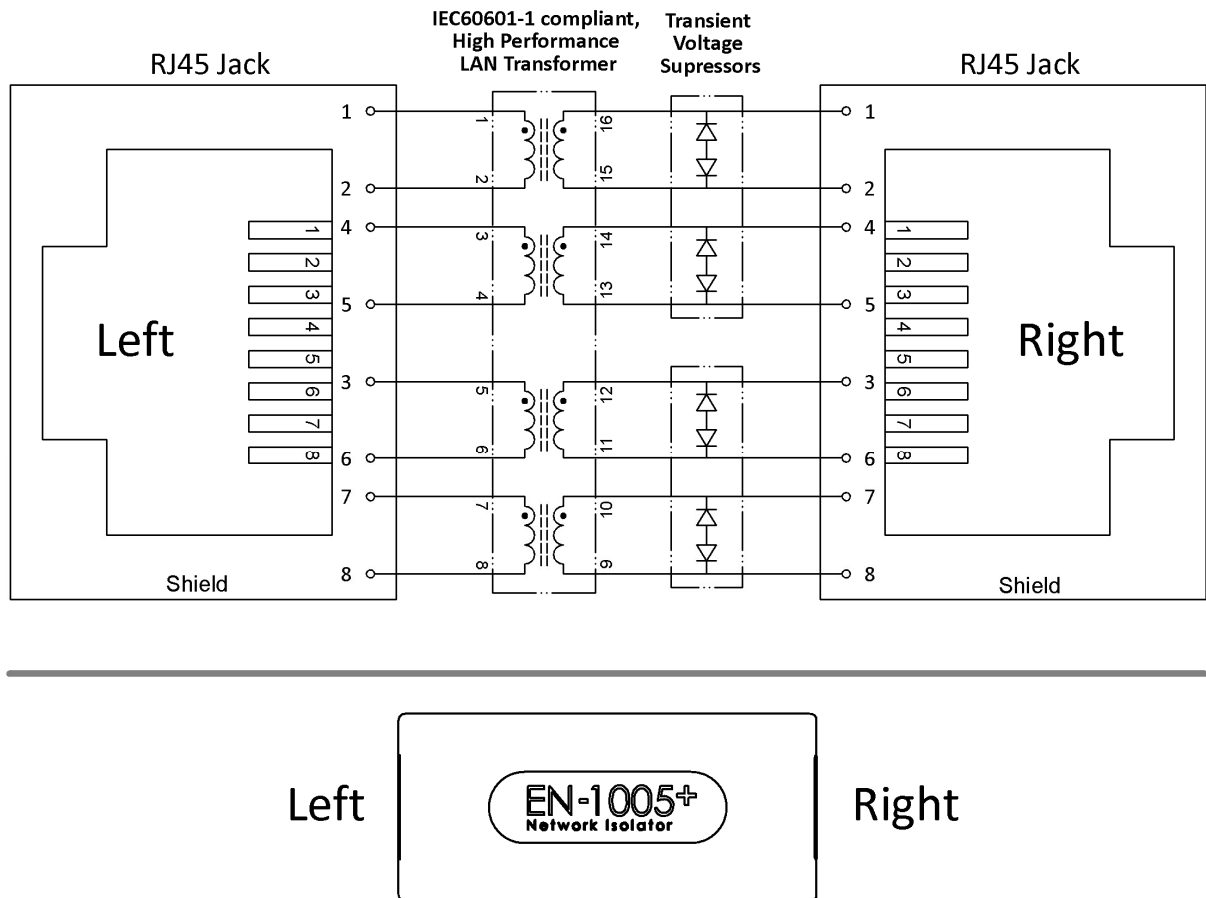







Figure 5. Schematic diagram of the EN-1005+.

10 SCHEDULED MAINTENANCE

EMOSAFE network isolators are maintenance-free when used as intended.

11 PRODUCT MARKINGS

	Through this mark, the conformity of the product with all applicable EU Directives is confirmed.
	Designates the product as a UL "Recognised Component"; File number E362969.
	The product may not be disposed of in domestic rubbish.
	This product contains no substances containing lead and is manufactured using lead-free solder.
	This product meets the requirements of EU Directive concerning the limitation of the use of certain hazardous substances in electric and electronic equipment.

12 ACCESSORIES

12.1 WALL MOUNTING PLATE Z-6W

With the Z-6W wall mounting plate, an EN-1005+ network isolator can be mounted on any flat surface. The Z-6W wall mounting plate has a releasable snap lock. Using a screwdriver, the snap latches on the narrow sides of the plastic plate can be pressed down to release the EN-1005+ again.

With a Z-6W wall mounting plate, the EN-1005+ can also be attached to ungrounded metallic surfaces. The protective effect of the network isolator is not affected, as the required insulation distances of at least 12 mm to the mounting surface are ensured.



Wall Mounting Plate Z-6W for EN-1005+

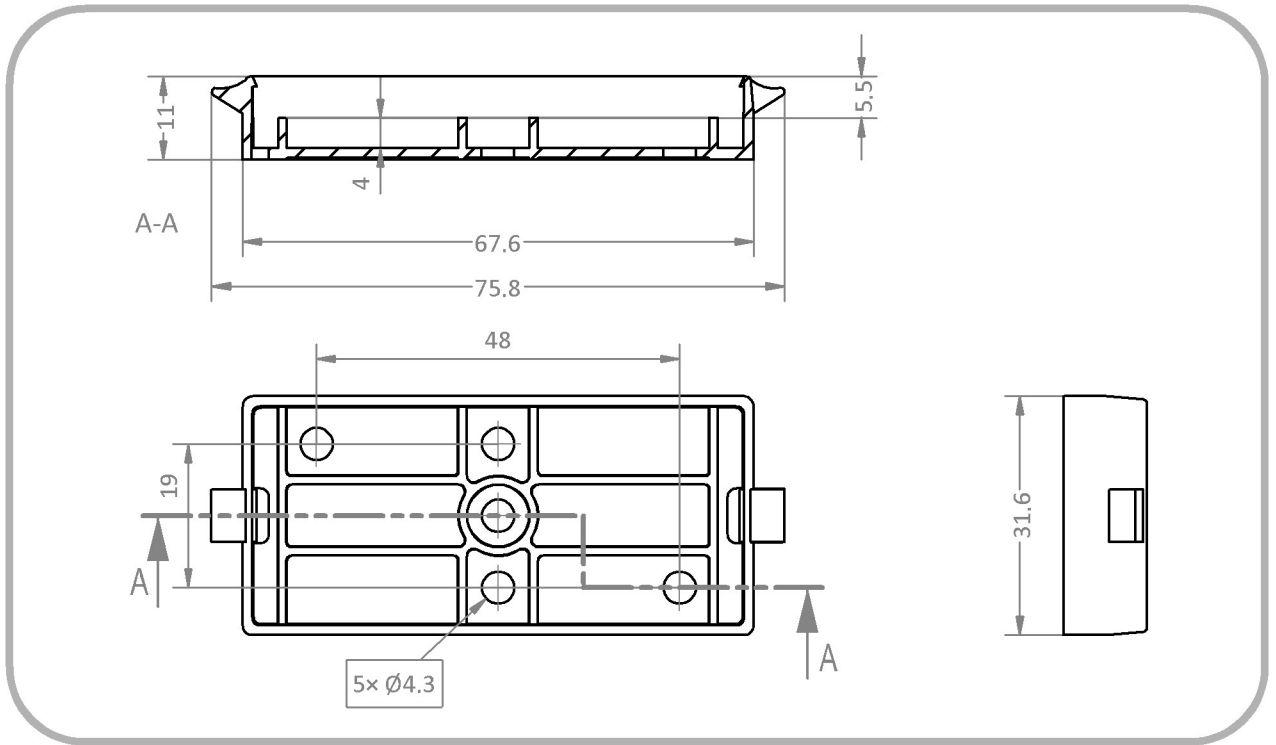

Dimensions of wall mounting plate Z-6W
All dimensions in millimeters

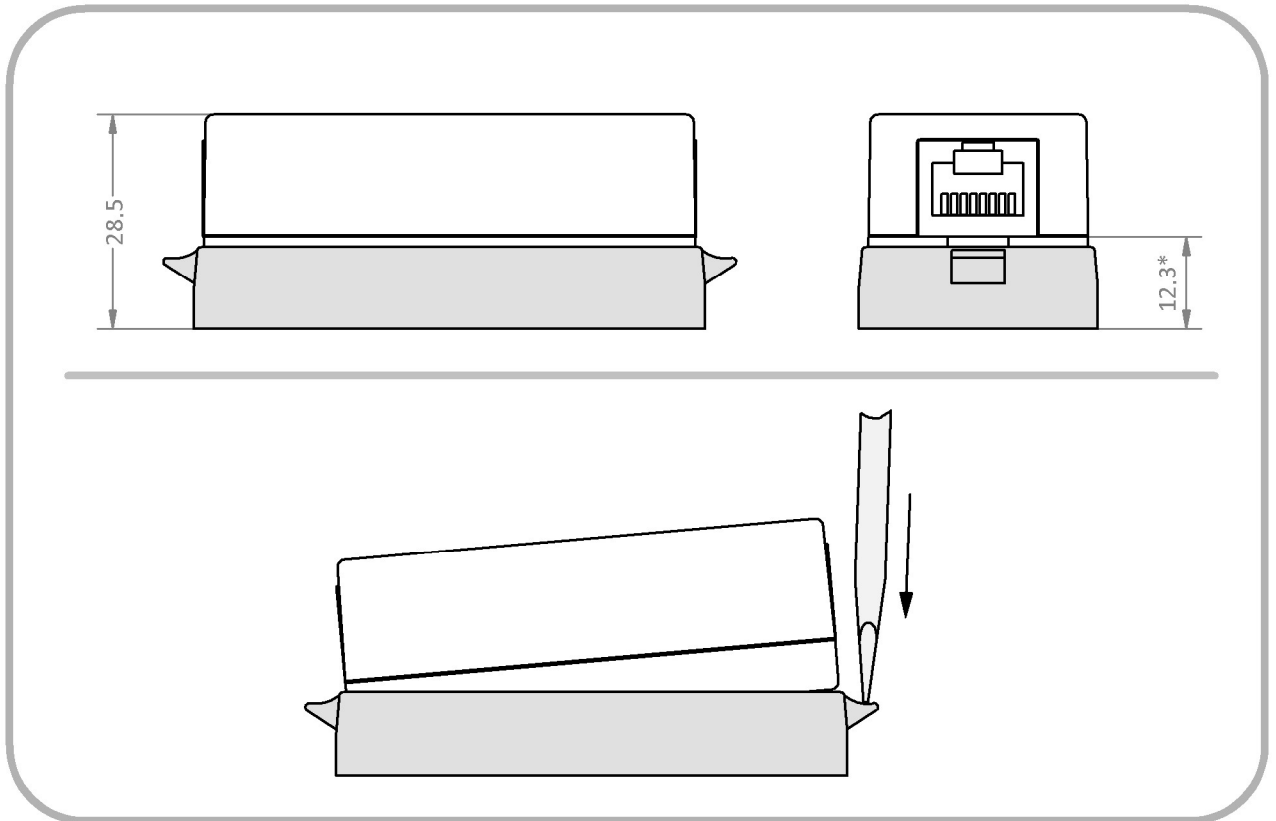

Mounting dimensions and unlocking of the Z6-W wall mounting plate
All dimensions in mm
Isolation distance between exposed metallic shield contacts and the mounting surface

12.2 DIN RAIL ADAPTER Z-6R

With the DIN rail adapter Z-6R, the EN-1005⁺ network isolator can be mounted on an EN 50022 standard 35 mm DIN rail. The Z-6R is based upon the Z-6W and has the same features for coupling and decoupling an EN-1005⁺. The required insulation distances to the top-hat rail and to neighboring devices are automatically ensured by the Z-6R top-hat rail adapter.



Network Isolator EN-1005⁺ with DIN rail adapter Z-6R

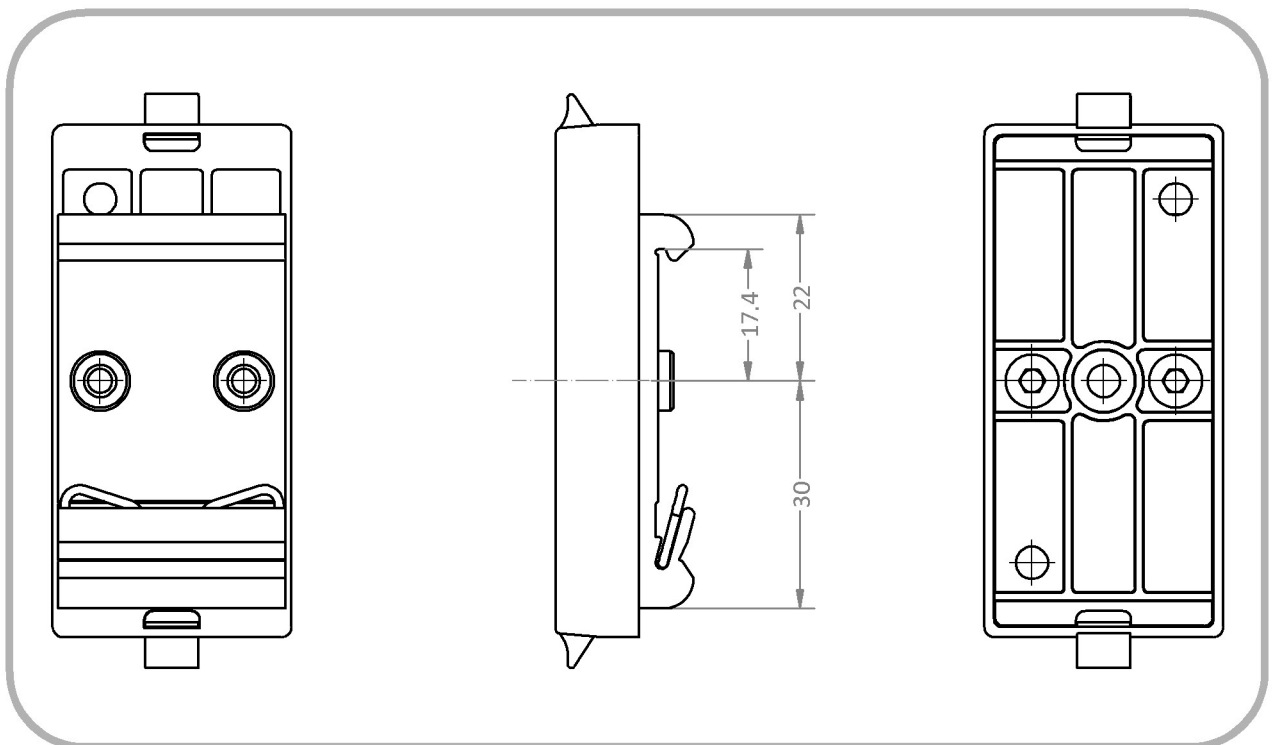

*Dimensions of DIN rail adapter Z-6R
All dimensions in millimeters*

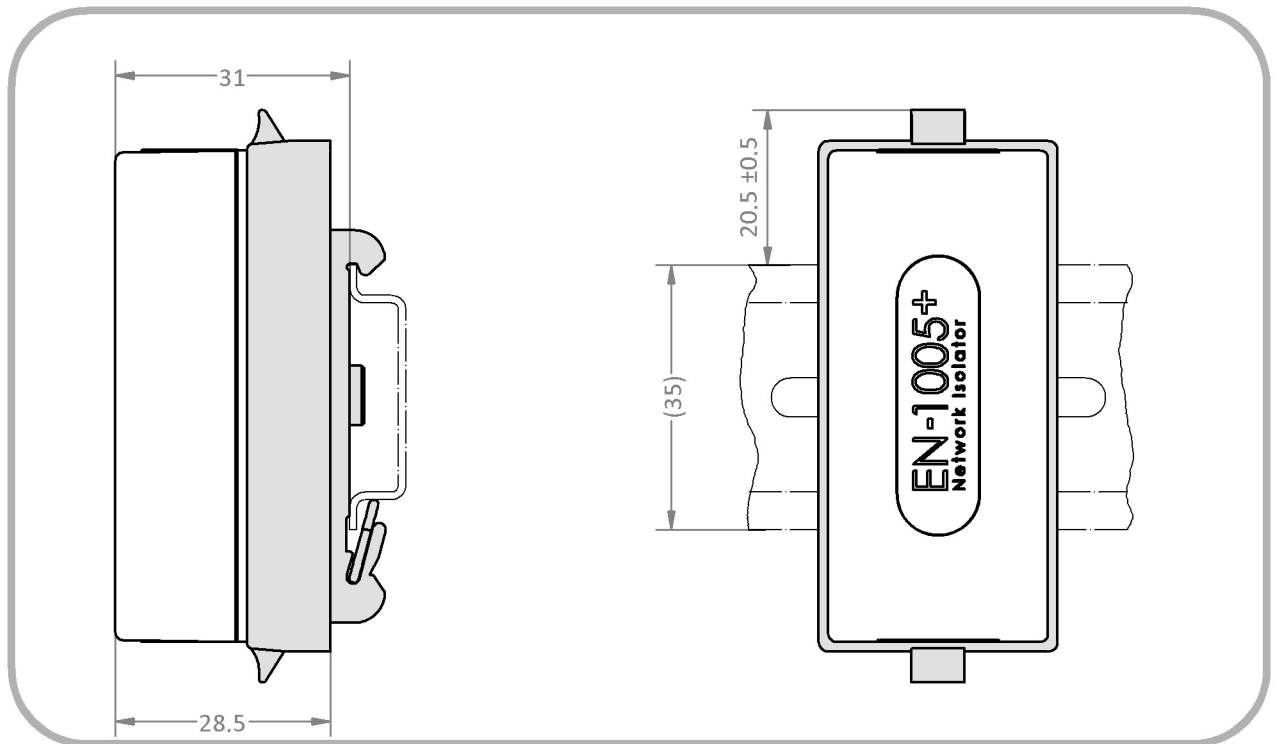

*Assembly dimensions for the DIN rail adapter Z-6R with EN-1005+
All dimensions in millimeters*

13 QUALITY

EMO Systems GmbH maintains a certified quality management system for development and production in accordance with ISO 9001 and ISO 13485. Every network isolator is subjected to extensive quality control before delivery. Among other things, it is checked whether the achieved values for leakage current, dielectric strength, insertion loss, return loss and near crosstalk (NEXT) correspond to the specifications.

You will also find a declaration of conformity on our website confirming that the EMOSAFE network isolators comply with the requirements of the Low Voltage Directive (2014/35/EU), the Electromagnetic Compatibility Directive (2014/30/EU) and the Restriction of Use Directive hazardous substances in electrical and electronic equipment (2011/65/EU, RoHS).

14 PACKAGING

The packaging label provides the following information:

- Article description
- Quantity
- Date of manufacture
- Ordering code (OC)
- Serial number as 1D- (Code 128) and a 2D barcode (Data Matrix)

Contents:

- A network isolator of type EN-1005⁺
- This data sheet

15 ENVIRONMENTAL PROTECTION INFORMATION

This device contains electronic components.

It must be returned to the manufacturer for disposal after use.

16 CONTACT AND SUPPORT

You can find the current contact details on our website: <https://emosystems.de/en/contact/>

Or you can reach us by email at the following address: support@emosystems.de

17 LEGAL NOTICE

The information in this data sheet has been compiled to the best of our knowledge and with all care. However, we cannot guarantee that they are complete and error-free.

The user is responsible and liable for the correct use of this product. Neither EMO Systems GmbH nor EMO Systems Inc. assume liability.

This data sheet is subject to change without prior notice.