

EMOSAFE EN-20G

Product Datasheet

Gigabit Network Isolator in robust plastic housing



1 FEATURES AND ADVANTAGES

- Gigabit Ethernet
- Robust plastic housing for wall for wall mounting
- Optionally usable mounting brackets
- IEC 60601-1 compliant
- UL Recognized Component
- RoHS compliant
- 4 kV AC dielectric strength
- 5.6 kV DC dielectric strength
- 100% inspection by our Quality Control

2 GENERAL DESCRIPTION

EMOSAFE EN-20G Network Isolators disconnect every electrically conducting connection (specifically the data and shield conductors) between devices connected together via a copper-based Ethernet network. The Network Isolators prevent current flow resulting from differences in electrical potentials, and also protect connected devices and their users from stray external voltages and power surges which may be directly or inductively coupled onto the network lines by causes such as installation errors, lightning, switching operations, and electrostatic discharge.

Built into a medical electrical (ME) device, the EMOSAFE EN-20G Network Isolator facilitates the safe Ethernet connection of this ME product within the patient environment. The EN-20G fulfils all the constructional requirements of IEC 60601-1, and forms two Means Of Patient Protection (2 MOPP) within the network interface, as well as practically eliminating the risk to patients and operators arising from electrical shocks created by stray voltages present on the network connection.

The EN-20G has a robust plastic housing, suitable for wall mounting. Included with the EN-20G are four assembly brackets which can be used to mount the Network Isolator to a wall or to a device panel. Alternatively, the EN-20G housing can be simply glued to a flat surface with a suitable adhesive. The EN-20G is further distinguished by its gigabit Ethernet capability, and also by its robust construction.

As a UL Recognized Component, the EN-20G Network Isolator is also suitable for inclusion in systems destined for export in the North American markets.

EMOSAFE Network Isolators transmit high-frequency signals through the principle of electromagnetic induction. Because of this, they do not require their own power supplies. There are no software drivers to be installed.

3 APPLICATIONS

3.1 PATIENT PROTECTION

Electrical separation of Ethernet interfaces of medical electrical (ME) devices and systems, where patients must be protected from dangerous leakage currents, in conformity with applicable standards.

3.2 EQUIPMENT PROTECTION

Applications, in which valuable devices or those requiring special protection need to be protected against ripple, mains hum, and surge voltages from the network periphery.

3.3 MEASUREMENT TECHNOLOGY

Electrical measuring and monitoring equipment, which needs to be protected against external voltages and interference voltages arising from the Ethernet periphery.

3.4 AUDIO

Audio applications, in which the transmission of low frequency alternating current voltages (mains hum) over the network connection is to be reduced to an imperceptible level.

4 TECHNICAL DRAWINGS

4.1 TECHNICAL DRAWINGS: EN-20G

All dimensions in mm.

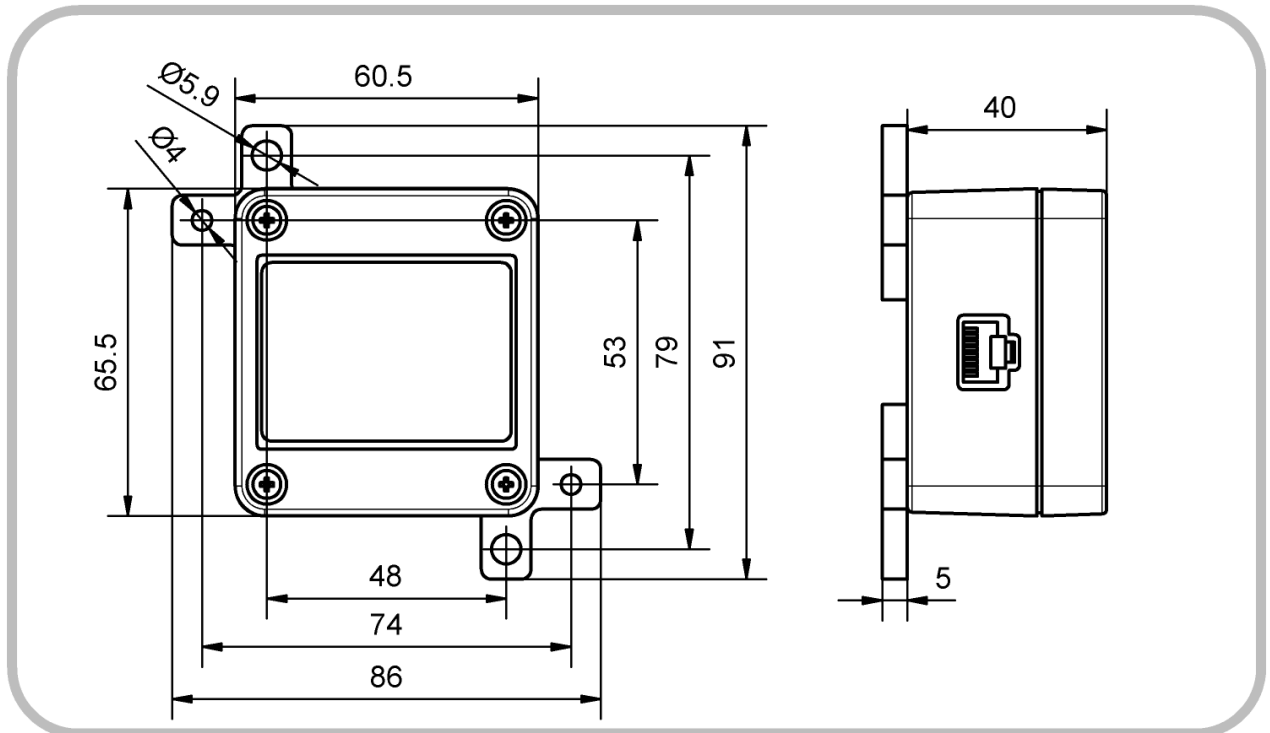

Figure 1. Physical dimensions of EN-20G, with mounting brackets

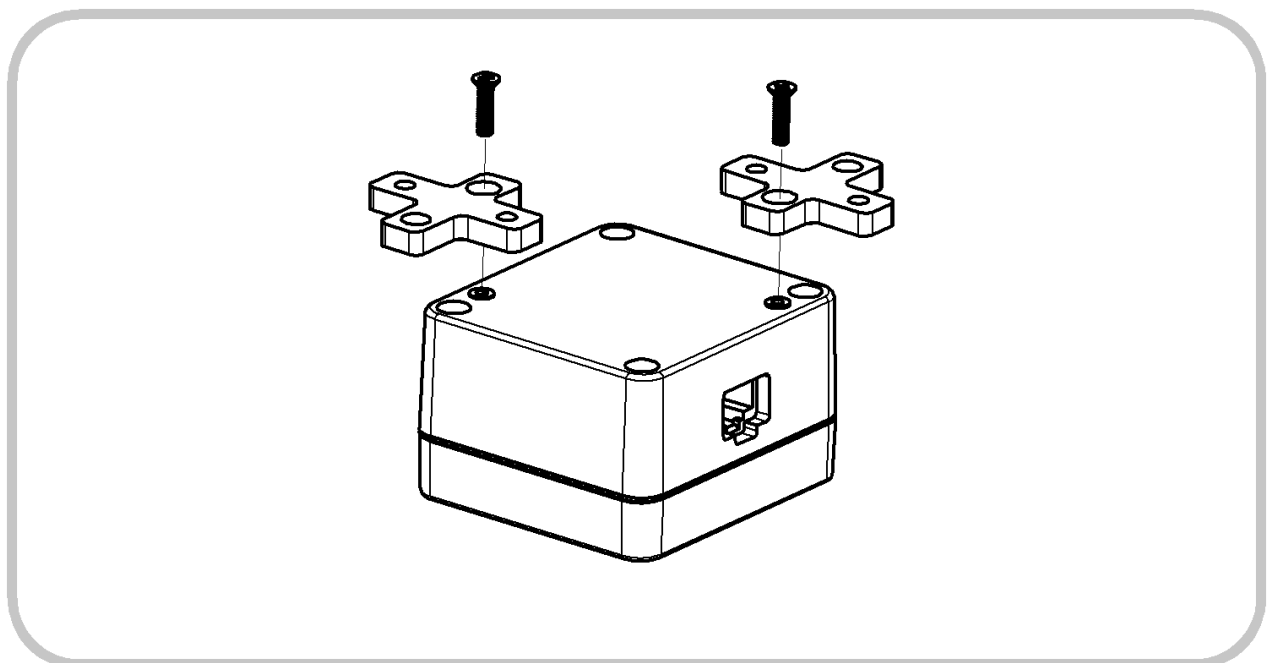

Figure 2. Assembly of the mounting brackets

5 INSTALLATION INFORMATION

5.1 GENERAL

EN-20G Network Isolators are designed for data transmission in the frequency range of 300 kHz to 100 MHz. Lower frequencies are strongly attenuated. For this reason, it is generally not possible to transmit the signals from nurse call systems, telephone systems or analogue audio / video signals over a Network Isolator.

The EN-20G Network Isolator can be used in a Power over Ethernet (PoE) network without restriction (however PoE devices downstream of the electrical isolation are not supplied with power). A PoE Injector can be installed to supply downstream devices, however it is critical that this power supply meets or exceeds all applicable medical electrical requirements, in order to maintain the effectivity of the Network Isolator.

5.2 EQUIPMENT INSTALLATION

When designing Network Isolators into equipment or devices, it is essential that the manufacturer observes the applicable creepage and clearance distances. Specifically, the creepage and clearance distances between exposed metal surfaces of Ethernet patch cables plugged into the Network Isolator, and the next-closest electrically conducting components of the equipment or device to be protected. The requirements of IEC60601-1 are particularly relevant.

6 SAFETY NOTICE

During assembly, attention should be paid (when applicable) to ensure that the clearance and creepage distances required by IEC 60601-1 are met. The isolating effect of the Network Isolator must not be compromised by neighbouring conductive components. If, for example, the installation of the Network Isolator is to be within a metal plate, this plate must be connected to the ground potential (protective earth).

As a matter of principle, Network Isolators should be mounted as close as possible to the equipment requiring protection.

Damaged Network Isolators, and Network Isolators which are contaminated by dust or liquids, are to be replaced.

7 FUNCTION AND SAFETY INSPECTIONS

7.1 FUNCTION AND COMPLIANCE TESTS

A cable run equipped with an EN-20G Network Isolator can be checked with regard to its transmission characteristics using cable certification devices which are suitable for testing an electrically isolated cable run. To be able to conduct such an inspection, the test equipment must be configured in an AC wire-map mode. With the installed Network Isolator, the entire cable run can be approved according to EIA/TIA-568 Cat.5e or ISO 11801 Class C. Testing of the cable shielding and the individual conductor resistance is not possible in such an AC test mode.

7.2 SAFETY INSPECTIONS

Regular safety inspections and post-repair inspections are not prescribed for Network Isolators in medical use, as Network Isolators themselves are not classified as medical electrical (ME) devices. However, together with a connected ME device, Network Isolators form part of an ME system, which altogether may be subject to statutory inspection. The test interval, as well as the requirements to be met for both regular safety inspections and post-repair inspections will be specified by the responsible organisation (e.g. manufacturer or operator as defined by the regulations), and based upon the applicable standards for the entire ME system.

To simplify implementation, the individual components of the ME system (in this case, the Network Isolator) can be tested separately. Here as well, the responsible organisation specifies the test parameters, test interval and in the event of a failed test, the consequences. Depending on the requirement profile, the test can include one or more of the following individual tests:

7.2.1 VISUAL INSPECTION

Check for evidence of external damage and ingress of substances; dust or liquids for example.

7.2.2 LEAKAGE CURRENT TEST

It is to be checked if the measured leakage current is still within the prescribed limits. For this purpose, test equipment which can perform equipment leakage current measurements in accordance with IEC 62353 may be used. To perform a leakage current test, all conductors on the input side must be short-circuited together, and all the conductors on the output side must also be short-circuited together. The AC test voltage specified by the responsible organisation is then applied across these two connections. Input and output sides are interchangeable. The expected current flow can be found in section [8 SPECIFICATIONS](#).

7.2.3 HIPOT TEST

To ensure that the device under test is not damaged, it is recommended that a DC voltage source is used in place of the AC voltage source, and that the DC voltage is 1½ times that of the required AC voltage. The test setup is essentially the same as that of the Leakage Current Test above. The expected dielectric strength can be found in section [8 SPECIFICATIONS](#).

7.2.4 FUNCTIONAL TEST

After conducting the tests above, and reconnecting the Network Isolator into the Ethernet network, it is recommended to check whether the signal transmission is still performing correctly. Such a functional test can be performed, for example, with a suitable Ethernet cable certification device. See also section [7.1 FUNCTION AND COMPLIANCE TESTS](#).

8 SPECIFICATIONS

8.1 GENERAL

Category	Standards or Test Criteria	Properties
Designation		EMOSAFE EN-20G
Housing colour		Beige
Housing Material		Plastic
Construction		Self-Enclosed
Mounting Arrangement		Screws
Input Interface		RJ45 Jack, straight
Output Interface		RJ45 Jack, straight
Weight		approximately 95 g
Protection rating	EN 60529	IP40
Mating cycles	RJ45 plug mating and disconnecting from RJ45 socket	> 250 cycles
Mean Time To Failure (MTTF)	SN 29500 Standard Temperature: 25°C Duty cycle: 100% (24 hours, 7 days)	4,590 years
	SN 29500 Standard Temperature: 40°C Duty cycle: 100% (24 hours, 7 days)	4,260 years

8.2 ETHERNET PERFORMANCE

Category	Standards or Test Criteria	EN-20G
Transmission Speeds and Supported Network Protocols	10 Mbit/s, 10Base-T (IEEE802.3 Cl.14)	✓
	100 Mbit/s, 100Base-Tx (IEEE802.3 Cl.25)	✓
	1000 Mbit/s, 1000Base-T (IEEE802.3 Cl.40)	✓ *
Performance Category	ISO 11801, Permanent Link (PL)	Class C
Insertion Loss (absolute)	Typical:	1.5 dB @ 100 MHz
	Maximum:	2.0 dB @ 100 MHz
Return Loss (absolute)	Typical:	8.0 dB @ 100 MHz
	Minimum:	6.0 dB @ 100 MHz

* Transmission speeds of 1 Gbit/s are generally easily achievable with high-quality cabling and modern Ethernet network cards. For standard-compliant signal paths at 1 Gbit/s, or for critical applications, we recommend utilising Network Isolators that satisfy the requirements of ISO 11801 Permanent Link Class D.

8.3 ELECTRICAL

Category	Standards or Test Criteria		EN-20G
AC Dielectric Strength	at 50 Hz, for 60 seconds		4.0 kV
DC Dielectric Strength	for 60 seconds		5.6 kV
Reinforced Isolation	IEC 60601-1		✓
Coupling Capacitance per Channel			12 pF ±25%
Total Coupling Capacitance			48 pF ±25%
Total Leakage Current	275 V AC at 50 Hz	Typical:	3.0 µA
		Maximum:	6.0 µA

8.4 OPERATING CONDITIONS AND AREA OF APPLICATION

Category	Standards or Test Criteria		EN-20G
Pollution Degree	IEC 61010		2 *
Overvoltage Category	IEC 60664-1		III
Maximum Working Voltage †	Maximum mains voltage of the connected devices, in accordance with IEC 60601-1		250 V AC 300 V DC
Temperature		Minimum:	+1°C
		Maximum:	+70°C
Air Humidity	Non-condensing	Minimum:	10%
		Maximum:	90%
Air Pressure		Minimum:	700 hPa
		Maximum:	1,060 hPa
Altitude		Maximum:	3,200 m

8.5 ENVIRONMENTAL CONDITIONS: STORAGE AND TRANSPORTATION

Category	Standards or Test Criteria		EN-20G
Temperature		Minimum:	-25°C
		Maximum:	+85°C
Air Humidity	Non-condensing	Minimum:	10%
		Maximum:	90%
Air Pressure		Minimum:	500 hPa
		Maximum:	1,060 hPa

* Normally only nonconductive pollution occurs. Temporary conductivity caused by condensation is to be expected.

† The Network Isolator can be permanently exposed to this voltage level.

8.6 CERTIFICATES

Category	EN-20G
UL Recognized Component	✓
UL File No.	E362969
IEC 60601-1	✓
IEC 60601-1-2	✓
ANSI/AAMI ES 60601-1	✓
CAN/CSA-C22.2 No. 60601-1	✓
Low Voltage Directive	✓
EMC Directive	✓
RoHS Directive	✓
Lead-free	✓

The versions of the cited standards and directives to which our products comply with can be found in our Declaration of Conformity and our UL certificate on our website under "[Standard Conformity and Certificates](#)".

8.7 ISOLATION DIAGRAM

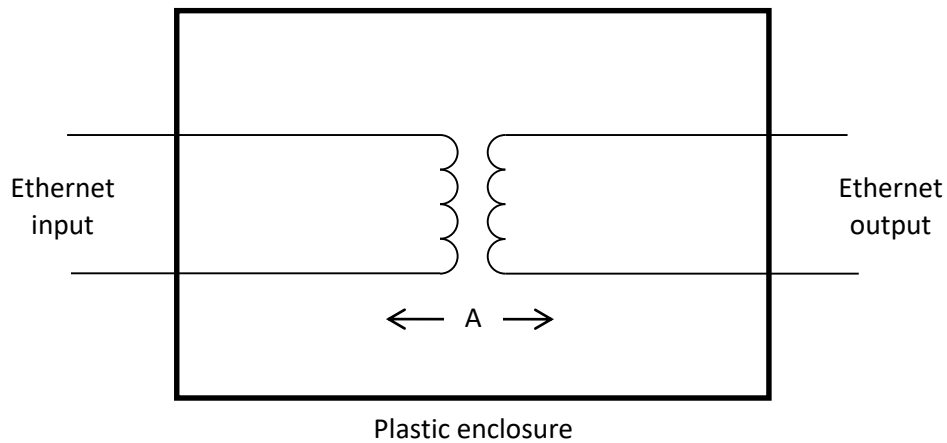

Figure 3. Isolation diagram for EN-20G

Area	Number and type of Means of Protection	Material Group (from CTI)	Maximum Operating Voltage		Required creepage distance (mm)	Required clearance distance (mm)	Measured creepage distance (mm)	Measured clearance distance (mm)
			V AC	V _{peak}				
A	2 MOPP *	IIIb †	250	353	8.0	5.0	9.0	9.0

8.8 FREQUENCY RESPONSE

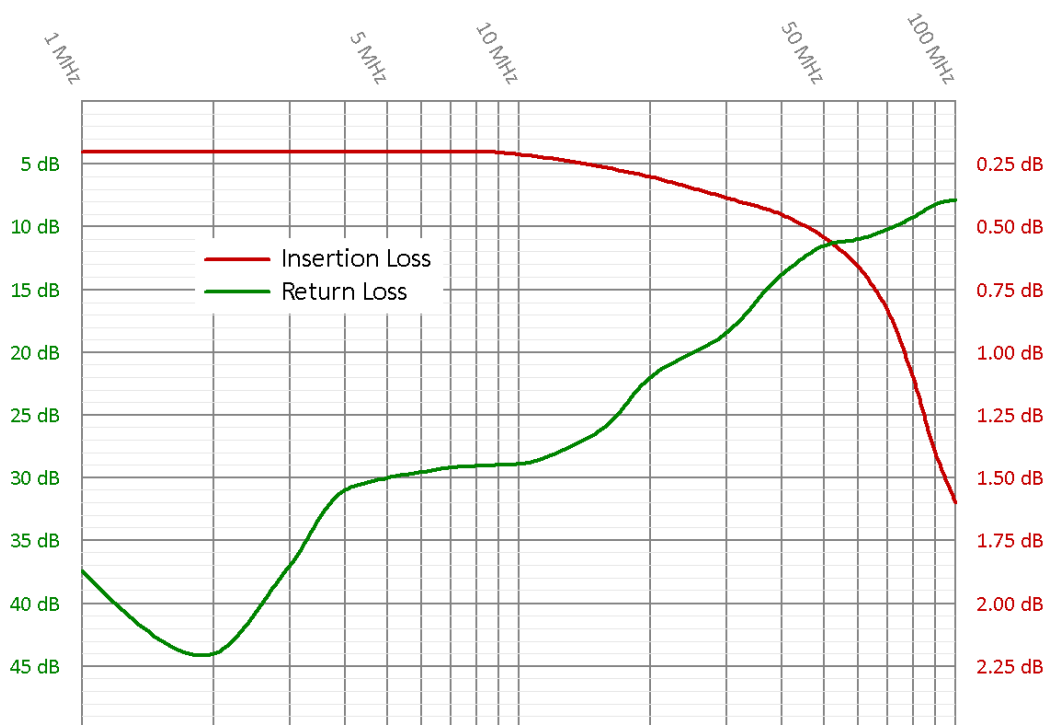

Figure 4. Typical frequency response for Insertion Loss and Return Loss of an EMOSAFE EN-20G Network Isolator.

* MOPP = Means of Patient Protection

† Materials in the Material Group IIIb have a Comparative Tracking Index (CTI) value between 100 and 175.

9 CIRCUIT DIAGRAM

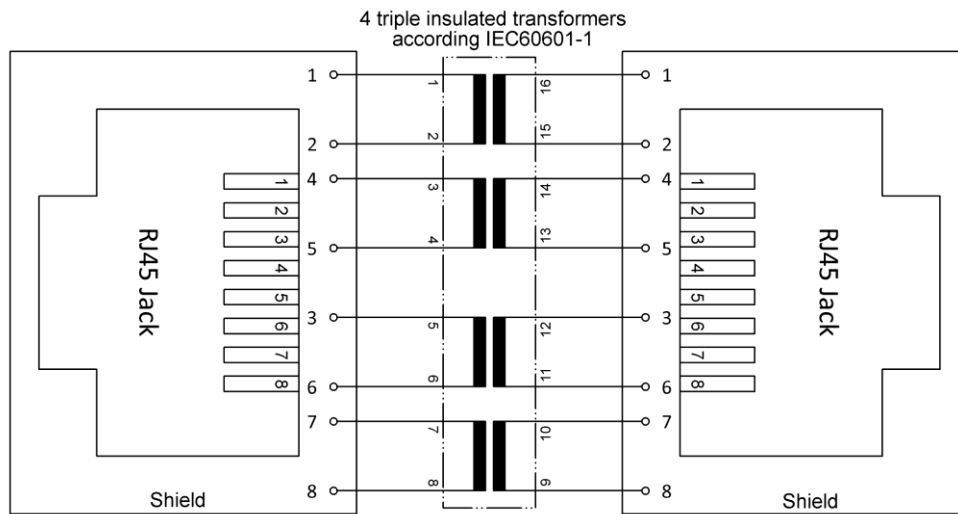

Figure 5. Circuit diagram for EN-20G

10 PACKAGING





Contents:

- Network Isolator. EN-20G
- 4 mounting brackets, including screws
- 2 wall plugs \varnothing 6 mm and screws for wall mounting

A packaging label provides the following information:

- Article description
- Quantity
- Ordering code (OC)
- Date of Manufacture
- Serial number
- The serial number is printed as both a 1D- (Code 128) and a 2D barcode (Data Matrix).

11 PRODUCT MARKINGS

	<p>Through this mark, the conformity of the product with all applicable EU Directives is confirmed.</p>
	<p>Designates the product as a UL "Recognised Component"; File number E362969.</p>
	<p>The product may not be disposed of in domestic rubbish.</p>
	<p>This product contains no substances containing lead and is manufactured using lead-free solder.</p>
	<p>This product meets the requirements of EU Directive concerning the limitation of the use of certain hazardous substances in electric and electronic equipment.</p>

12 SCHEDULED MAINTENANCE

When used as directed, EMOSAFE Network Isolators are maintenance-free.

13 ENVIRONMENTAL PROTECTION INFORMATION

This device contains electronic components. At the end of its service life it is to be returned to the manufacturer for disposal.

14 QUALITY

EMO Systems operates a certified quality management system for development and production in accordance with ISO 9001 and ISO 13485. Prior to delivery, each Network Isolator is subjected to a comprehensive quality inspection. This inspection ensures, among other factors, that the attained values for leakage currents, dielectric withstand strengths, insertion losses, return losses, and near end crosstalk values all meet the specified requirements.

15 CONTACT AND SUPPORT

Please find our up-to-date contact details on our website: <http://www.emosystems.de/en/contact>

Or send us an e-mail at the following address: support@emosystems.de

16 LEGAL NOTIFICATION

The information provided above in this datasheet has been compiled with all due care, and is believed to be accurate and reliable. However, we cannot guarantee that the information contained is completely free from error.

The end user is responsible and liable for the proper use of this product; EMO Systems assume no liability. We reserve the right to make changes to this datasheet without notice.