

EMOSAFE EN-10

Product Datasheet

Network Isolators with Protected Connector



1 FEATURES AND ADVANTAGES

- Robust socket
- Touch protection and strain relief *
- Protection class IP67 attainable *
- Gigabit Ethernet †
- Conforms to IEC 60601-1
- UL Recognized Component
- RoHS compliant
- Suitable for devices with supply voltages up to 250 V AC or 300 V DC
- Dielectric strength 4.0 kV AC or 5.6 kV DC
- 100% quality control testing

2 GENERAL DESCRIPTION

The EMOSAFE EN-10 Network Isolator disconnects every electrically conducting connection (specifically the data and shield conductors) between devices connected via a copper-based Ethernet network. The Network Isolator prevents current flow resulting from differences in electrical potentials, and protects connected devices and their users from stray external voltages and power surges which may be directly or inductively coupled onto the network lines by causes such as installation errors, lightning, switching operations, and electrostatic discharge.

Built into a medical electrical (ME) product, the EMOSAFE EN-10 Network Isolator facilitates the safe Ethernet connection of this ME product within the patient environment. The EN-10 satisfies all construction requirements of IEC 60601-1 in the formation of two means of patient protection (MOPP) within the

* With accessory Z-1

† Only EN-10HG and EN-10VG. EN-10V and EN-10H transmit a maximum of 100 Mbit/s

network interface, thereby practically eliminating the risk of electrical shocks arising from such stray external voltages at the network connection.

The EN-10 possesses an extremely robust waterproof and dustproof connector. When build into a suitably protected housing, and when used in combination with the optionally available IP67 Plug Housing Z-1, the EN-10 reaches the protection class IP67. Additionally, the IP67 Plug Housing Z-1 offers an additional strain relief. The EMOSAFE EN-10 is thereby also suitable for application in devices used outdoors, as well as in environments where exceptional mechanical loads and strains are placed upon the connector or cable.



Figure 1. Z-1 and EN-10

Furthermore, the isolated construction of Z-1 offers an effective touch guard, so that a medical electrical appliance fitted with an EN-10 will pass inspection when tested with a test finger in accordance with the standard IEC 60601-1, even when a network cable is connected.

The isolated IP67 Plug Housing Z-1 also prevents conducting metal parts from being touched during the connection process. This is especially important for devices which have their interface connection within the patient environment, and where it cannot be ruled out that the operator may be in electrical contact with the patient, through bodily contact or otherwise, during the processes of connection and disconnection.

The application of the IP67 Plug Housing Z-1 is optional. Alternatively, a market-standard RJ45 patch cable may be used, as shown in Figure 2.

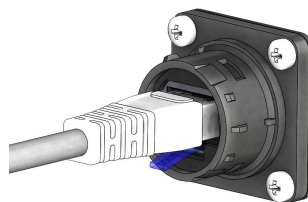

Figure 2. EN-10 and patch cable

With the help of the IP67 Dust Cap Z-2, unused network connections may be closed and sealed against dust and water, as indicated in Figure 3.



Figure 3. EN-10 and Z-2

Network Isolators of the EMOSAFE EN-10 series support data transmission rates of 10 Mbit/s, 100 Mbit/s, and 1000 Mbit/s*, and have the distinction of an especially minimal insertion loss. With their UL approval, they are also suitable for devices destined for export to the North American markets. The EN-10 is available in either of two mechanical forms: the rear termination being either straight, or at 90°.

Low-frequency signal components are strongly attenuated, so that connected devices may, for example, be protected against ground loops.

EMOSAFE Network Isolators transmit high-frequency signals through the principle of electromagnetic induction. Because of this, they do not require their own power supplies. There are no software drivers to be installed.

3 APPLICATIONS



- **Patient protection**
Electrical separation of Ethernet interfaces of medical electrical (ME) devices and systems, where patients must be protected from dangerous leakage currents, in conformity with applicable standards.
- **Equipment protection**
Applications, in which valuable devices or those requiring special protection need to be protected against ripple, mains hum, and surge voltages from the network periphery.
- **Measurement technology**
Electrical measuring and monitoring equipment, which needs to be protected against external voltages and interference voltages arising from the Ethernet periphery.
- **Potential differences (Technical building systems)**
Computer systems, which are electrically connected with each other over significant distances via Ethernet cabling, where current flows caused by potential differences must be prevented.
- **Power over Ethernet (PoE)**
The Network isolators can be used in a PoE network without restrictions, but PoE end devices cannot be supplied with voltage behind the location of the galvanic isolation.

* 1000 Mbit/s transfer rates only available on EN-10HG and EN-10VG

4 SUMMARY OF VARIANTS

EN-10

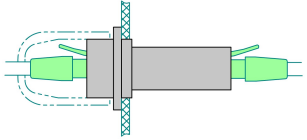
Network Isolators for inclusion in devices

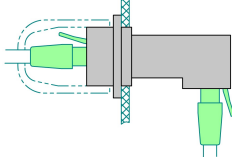
	Model and Article Number	Special features	AC dielectric strength (kV)	Gigabit-Ethernet	Typical Return Loss (dB) @ Limiting Frequency	Typical Insertion Loss (dB) @ Limiting Frequency	Configuration
Straight 	EN-10H A10009	Robust socket connection IP67 protection*	4	✗	12 @ 16 MHz	0.5 @ 16 MHz	
	EN-10HG A10005	Touch protection* Straight internal jack socket	4	✓	15 @ 100 MHz	0.8 @ 100 MHz	
Right Angled 	EN-10V A10008	Robust socket connection IP67 protection*	4	✗	12 @ 16 MHz	0.5 @ 16 MHz	
	EN-10VG A10004	Touch protection* Right angled internal jack socket	4	✓	15 @ 100 MHz	0.8 @ 100 MHz	

* When used in conjunction with accessories Z-1 or Z-2. Refer to section 13 ACCESSORIES

5 DRAWINGS

All dimensions in millimetres.

5.1 EN-10HG AND EN-10H

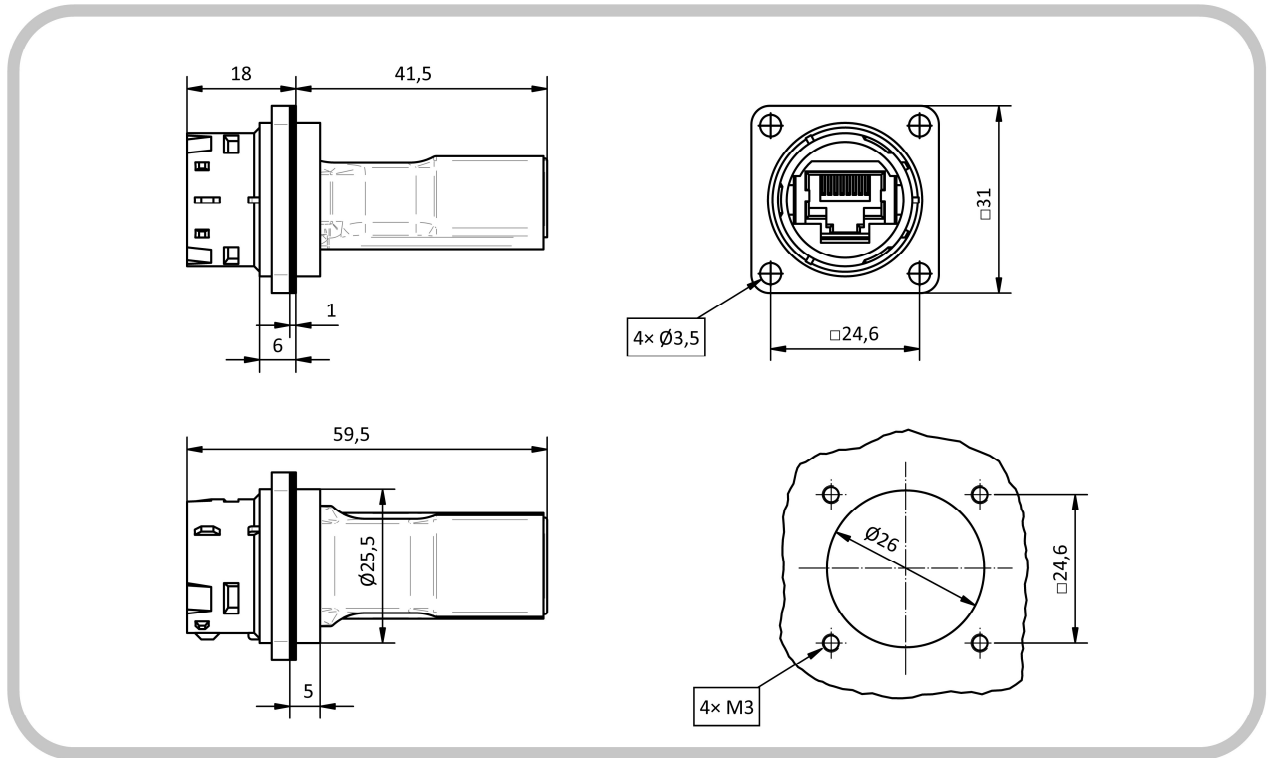
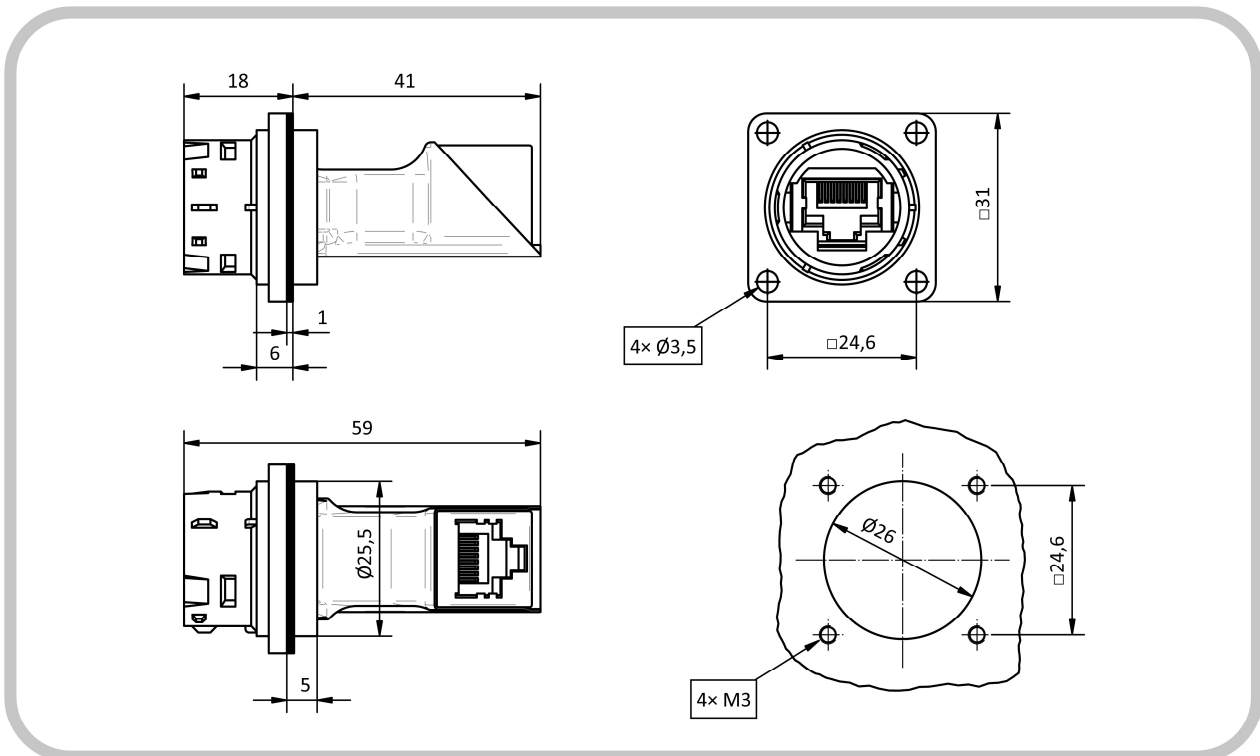

Figure 4. Physical dimensions of EN-10HG and EN-10H

5.2 EN-10VG AND EN-10V



Physical dimensions of EN-10VG and EN-10V

6 ASSEMBLY INSTRUCTIONS

6.1 ASSEMBLY DRAWING

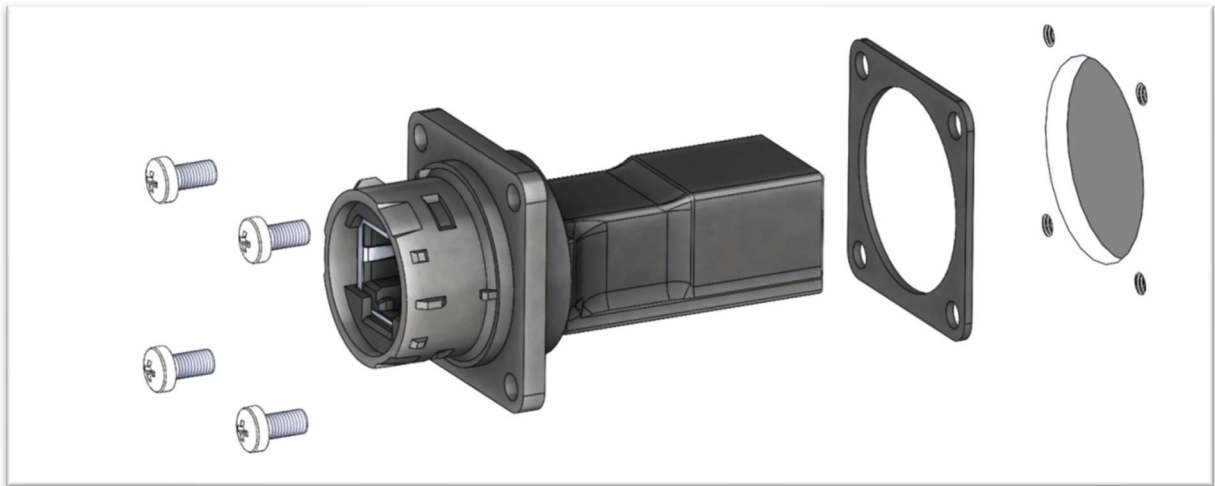

Figure 5. Assembly of EN-10HG into a housing panel opening

6.2 GENERAL

EN-10HG and EN-10VG Network Isolators are designed for data transmission in the frequency range of 300 kHz to 100 MHz (non-gigabit Network Isolators only up to 16 MHz). Lower frequencies are strongly attenuated. For this reason, it is generally not possible to transmit the signals from nurse call systems, telephone systems or analogue audio / video signals over a Network Isolator.

EN-10 Network Isolators can be used in a Power over Ethernet (PoE) network without restriction (however PoE devices downstream of the electrical isolation are not supplied with power).

6.3 INSTALLATION

EN-10 Network Isolators interrupt the shield connection. If the cable shield of the incoming data cable is to be connected with the room or equipment potential, such a connection must be carried out separately before the Network Isolator.

7 SAFETY NOTICE

During assembly, attention should be paid (when applicable) to ensure that the clearance and creepage distances required by IEC 60601-1 are met. The isolating effect of the Network Isolator must not be compromised by neighbouring conductive components. If, for example, the installation of the Network Isolator is to be within a metal plate, this plate must be connected to the ground potential (earth conductor).

As a matter of principle, Network Isolators should be mounted as close as possible to the equipment requiring protection.

Damaged Network Isolators, and Network Isolators which are contaminated by dust or liquids, are to be replaced.

8 FUNCTION AND SAFETY INSPECTIONS

8.1 FUNCTION AND COMPLIANCE TESTS

A cable run equipped with an EN-10HG or EN-10VG Network Isolator can be checked with regard to its transmission characteristics using cable certification devices which are suitable for testing an electrically isolated cable run. To be able to conduct such an inspection, the test equipment must be configured in an AC wire-map mode. With the installed Network Isolator, the entire cable run can be approved according to EIA/TIA-568 Cat.5e or ISO 11801 Class C (EN-10H/G) or Class D (EN-10HG/VG). Testing of the cable shielding and the individual conductor resistance is not possible in such an AC test mode.

8.2 SAFETY INSPECTIONS

Regular safety inspections and post-repair inspections are not prescribed for network isolators in medical use, as network isolators themselves are not classified as medical electrical (ME) devices. However, together with a connected medical device, network isolators form an ME system, which altogether may be subject to inspection. The test interval, as well as the requirements to be met for both regular safety inspections and post-repair inspections will be specified by the responsible organisation (as defined in IEC 60601-1) and based upon the applicable standards for the entire ME system.

To simplify implementation, the system components (in this case, the network isolator) can be individually tested. The responsible organisation provides the test parameters and test interval. Such an assessment may, depending upon requirements, include the following checks:

8.2.1 VISUAL INSPECTION

Check for evidence of external damage and ingress of substances; dust or liquids for example.

8.2.2 LEAKAGE CURRENT TEST

It is to be checked if the measured leakage current is still within the prescribed limits. For this purpose, test equipment which can perform equipment leakage current measurements in accordance with IEC 62353 may be used. To perform a leakage current test, all conductors on the input side must be short-circuited together, and all the conductors on the output side must also be short-circuited together. The AC test voltage specified by the responsible organisation is then applied across these two connections. Input and output sides are interchangeable. The expected current flow can be found in section **9 SPECIFICATIONS**.

8.2.3 HIPOT TEST

To ensure that the device under test is not damaged, it is recommended that a DC voltage source is used in place of the AC voltage source, and that the DC voltage is 1½ times that of the required AC voltage. The test setup is essentially the same as that of the Leakage Current Test above. The expected dielectric strength can be found in section **9 SPECIFICATIONS**.

8.2.4 FUNCTIONAL TEST

After conducting the tests above, and reconnecting the Network Isolator into the network, it is meaningful to examine whether the signal transmission is still performing correctly. Such a functional test can be performed, for example, with a suitable Ethernet cable certification device.

9 SPECIFICATIONS

9.1 GENERAL

Category	Standards or Test Criteria	Properties	
Designation		EMOSAFE EN-10(...)	
Housing colour		Black	
Housing Material		Plastic	
Construction		Panel Mount	
Mounting Arrangement		Screws	
Input Interface		RJ45 Jack, straight	
Output Interface		RJ45 Jack, straight (EN-10H, EN-10HG) RJ45 Jack, angled (EN-10V, EN-10VG)	
Weight		approximately 25 g	
Protection rating	EN 60529	IP20, or up to IP67 when assembled and used in combination with Z-1 or Z-2	
Mating cycles	RJ45 plug mating and disconnecting from RJ45 socket	> 250 cycles	
Mean Time To Failure (MTTF)	SN 29500 Standard Temperature: 25°C Duty cycle: 100% (24 hours, 7 days)	EN-10H/V:	6,950 years
		EN-10HG/VG:	4,590 years
	SN 29500 Standard Temperature: 40°C Duty cycle: 100% (24 hours, 7 days)	EN-10H/V:	6,560 years
		EN-10HG/VG:	4,260 years

9.2 ETHERNET PERFORMANCE

Category	Standards or Test Criteria	EN-10H/V	EN-10HG/VG
Transmission Speeds and Supported Network Protocols	10 Mbit/s, 10Base-T (IEEE802.3 Cl.14)	✓	✓
	100 Mbit/s, 100Base-Tx (IEEE802.3 Cl.25)	✓	✓
	1000 Mbit/s, 1000Base-T (IEEE802.3 Cl.40)	✗	✓ *
Performance Category	ISO 11801, Permanent Link (PL)	Class C	Class D
Insertion Loss (absolute)	Typical:	0.5 dB @ 16 MHz	0.8 dB @ 100 MHz
	Maximum:	0.8 dB @ 16 MHz	1.5 dB @ 100 MHz
Return Loss (absolute)	Typical:	12.0 dB @ 16 MHz	15.0 dB @ 100 MHz
	Minimum:	9.0 dB @ 16 MHz	12.0 dB @ 100 MHz

9.3 ELECTRICAL

Category	Standards or Test Criteria	EN-10H/V	EN-10HG/VG
AC Dielectric Strength	at 50 Hz, for 60 seconds	4.0 kV	4.0 kV
DC Dielectric Strength	for 60 seconds	5.6 kV	5.6 kV
Reinforced Isolation	IEC 60601-1	✓	✓
Coupling Capacitance per Channel		15 pF max.	37.5 pF ±25%
Total Coupling Capacitance		30 pF max.	150 pF ±25%
Total Leakage Current	275 V AC at 50 Hz	Typical:	2.0 µA
		Maximum:	5.0 µA
			12.0 µA
			16.0 µA

9.4 OPERATING CONDITIONS

Category	Standards or Test Criteria	EN-10H/V	EN-10HG/VG
Pollution Degree	IEC 61010	2 *	2 *
Overvoltage Category	IEC 60664-1	III	III
Maximum Working Voltage †	Maximum mains voltage of the connected devices, in accordance with IEC 60601-1	250 V AC 300 V DC	250 V AC 300 V DC
Temperature		Minimum:	-10°C
		Maximum:	+70°C
Air Humidity	Non-condensing	Minimum:	10%
		Maximum:	90%
Air Pressure		Minimum:	700 hPa
		Maximum:	1,060 hPa
Altitude		Maximum:	3,200 m

* Transmission speeds of 1 Gbit/s are generally easily achievable with high-quality cabling and modern Ethernet network cards. For standard-compliant signal paths at 1 Gbit/s, or for critical applications, we recommend utilising Network Isolators that satisfy the requirements of ISO 11801 Permanent Link Class D.

* Normally only nonconductive pollution occurs. Temporary conductivity caused by condensation is to be expected.

† The Network Isolator can be permanently exposed to this voltage level.



9.5 ENVIRONMENTAL CONDITIONS

Category	Standards or Test Criteria	EN-10H/V	EN-10HG/VG	
Temperature		Minimum:	-25°C	-25°C
		Maximum:	+85°C	+85°C
Air Humidity	Non-condensing	Minimum:	10%	10%
		Maximum:	90%	90%
Air Pressure		Minimum:	500 hPa	500 hPa
		Maximum:	1,060 hPa	1,060 hPa

9.6 CERTIFICATIONS

Category	EN-10H/V	EN-10HG/VG
UL Recognized Component	✓	✓
UL File No.	E362969	E362969
IEC 60601-1	✓	✓
IEC 60601-1-2	✓	✓
ANSI/AAMI ES 60601-1	✓	✓
CAN/CSA-C22.2 No. 60601-1	✓	✓
Low Voltage Directive	✓	✓
EMC Directive	✓	✓
RoHS Directive	✓	✓
Lead-free	✓	✓

The versions of the cited standards and directives to which our products comply with can be found in our Declaration of Conformity and our UL certificate on our website under "[Standard Conformity and Certificates](#)".

9.7 FREQUENCY RESPONSE

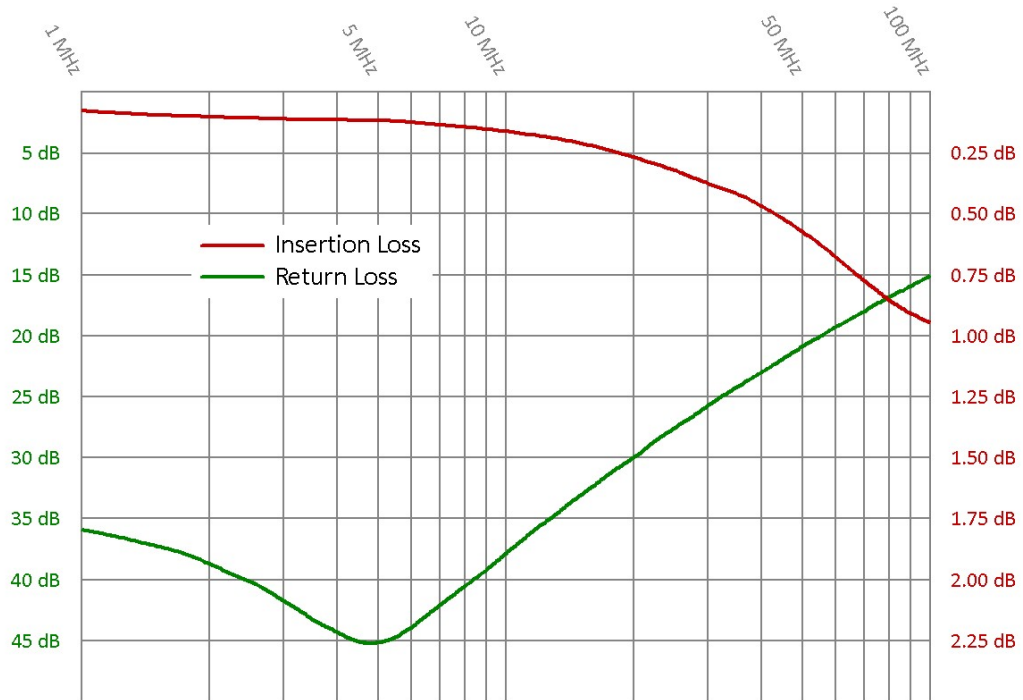

Figure 6. Typical frequency response for Insertion Loss and Return Loss of an EMOSAFE EN-10HG Network Isolator.

10 SCHEMATIC DIAGRAMS

10.1 EN-10HG AND EN-10VG

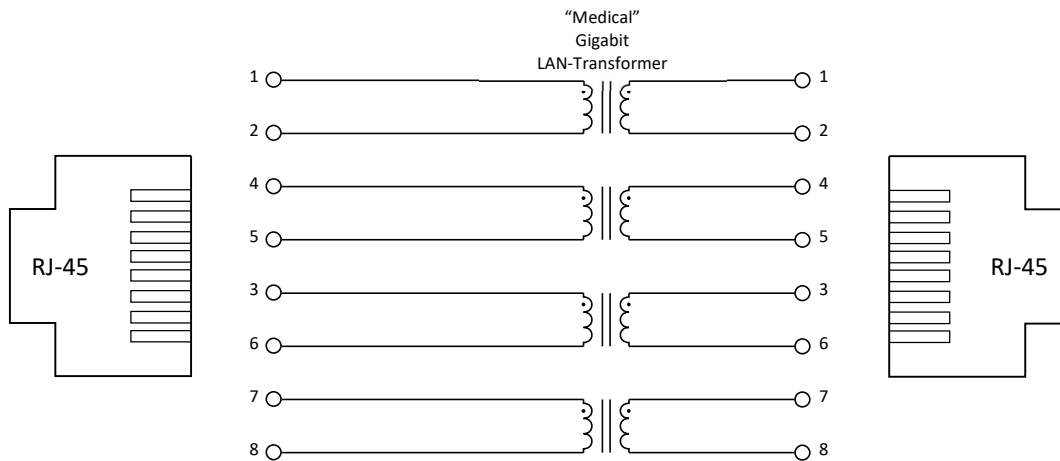
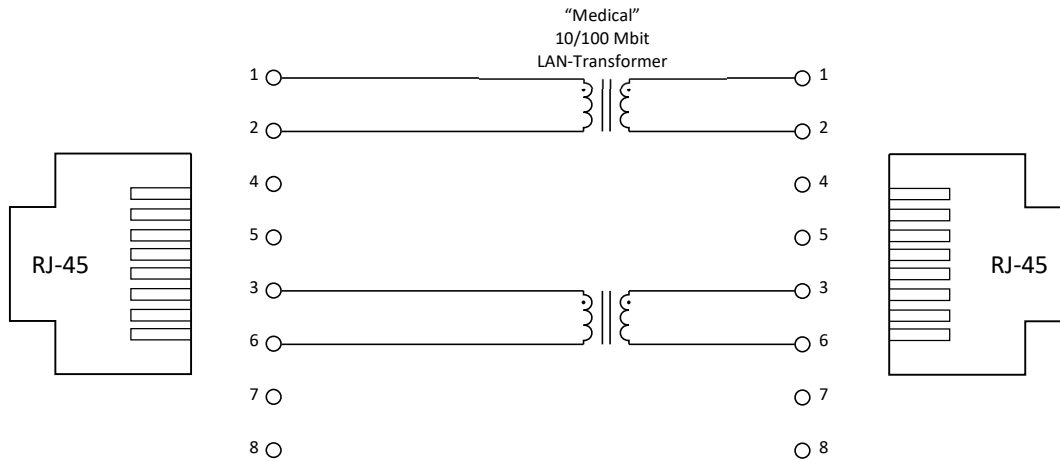

Figure 7. Schematic diagram for EN-10HG and EN-10VG

10.2 EN-10H AND EN-10V







Schematic diagram for EN-10H and EN-10V

11 SCHEDULED MAINTENANCE



EMOSAFE network isolators are maintenance-free when used as intended.

12 PRODUCT MARKINGS

	<p>Through this mark, the conformity of the product with all applicable EU Directives is confirmed.</p>
	<p>Marks the product as a UL "Recognised Component"; File № E362969.</p>
	<p>The product may not be disposed of in domestic rubbish.</p>
	<p>This product meets the requirements of EU Directive concerning the limitation of the use of certain hazardous substances in electric and electronic equipment.</p>

13 ACCESSORIES

13.1 OVERVIEW

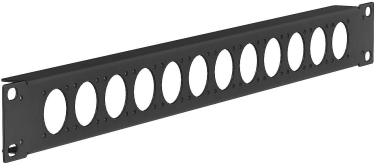
	Model and Article Number	Special features
<p>IP67 Plug Housing</p> 	<p>Z-1 A10012</p>	<ul style="list-style-type: none"> • Simple retrofitting of an existing patch cable • Protects against water and dust in accordance with IP67 • Touch protection • Mechanical protection of the plug connection • Material: glass fiber reinforced plastic, black
<p>IP67 Dust Cap</p> 	<p>Z-2 A10013</p>	<ul style="list-style-type: none"> • Protects against water and dust in accordance with IP67 • Mechanical protection of the mating connection • Material: glass fiber reinforced plastic, black
<p>19" Patch Panel</p> 	<p>Z-EN10-RP A10039</p>	<ul style="list-style-type: none"> • Provides mounting locations for 12 × EN-10 Network Isolators • Material: steel • Coating: matt black powder coated

13.2 IP67 PLUG HOUSING Z-1

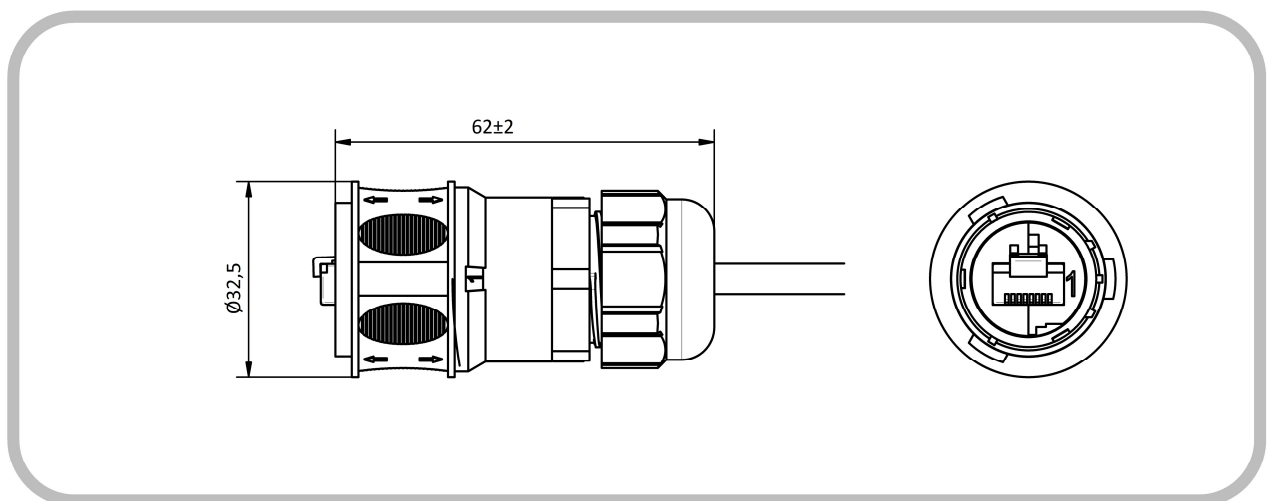

Dimensions of Z-1, assembled

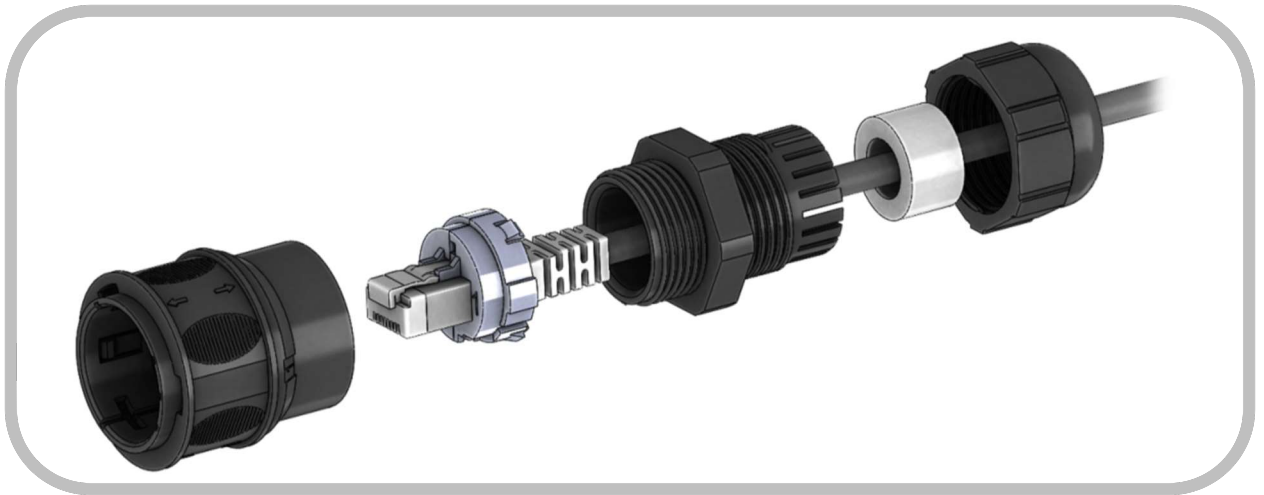

Assembly of Z-1 onto a patch cable

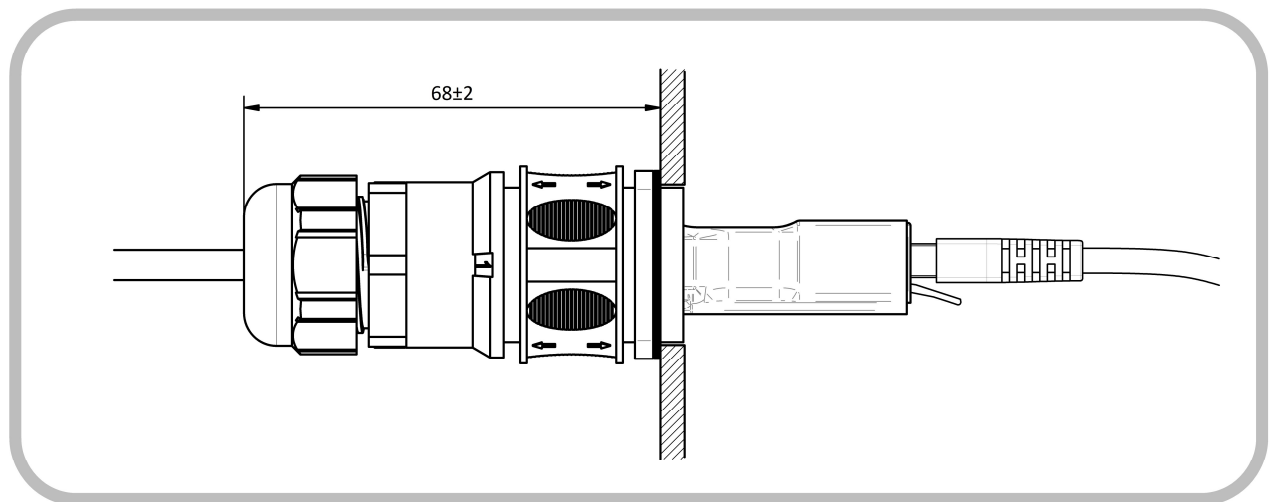

Assembly height of EN-10HG with Z-1

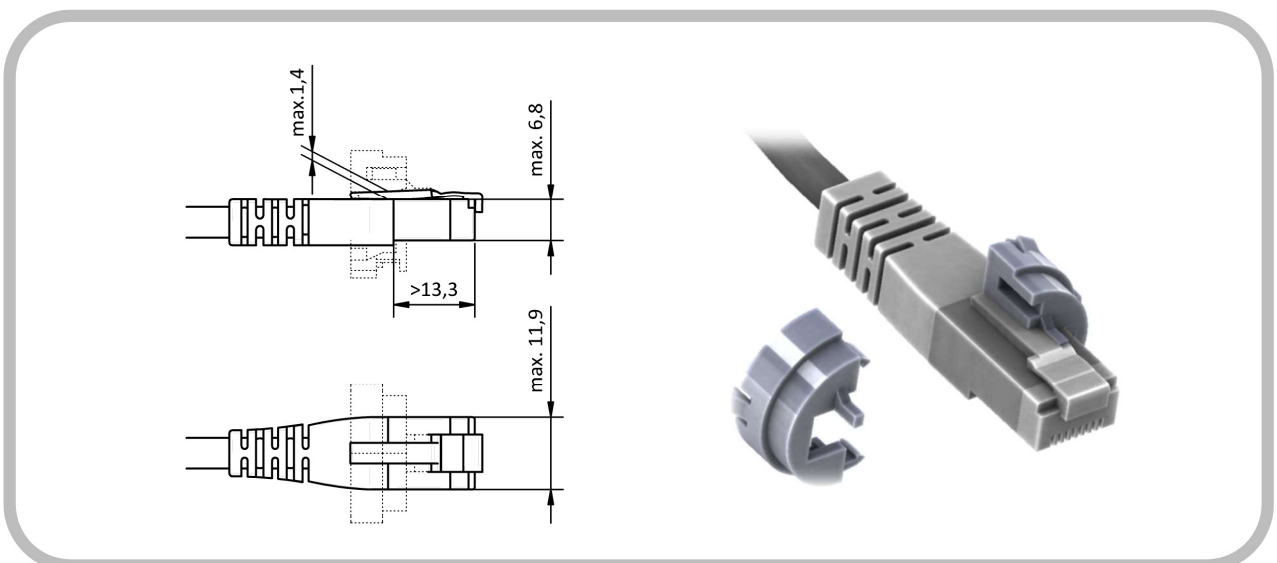

Z-1 Recommended dimensions of the RJ45 plug

NOTE: The IP67 Plug Housing Z-1 cannot be combined with every patch cable. We will be happy to help you choose a suitable patch cable. The drawing above serves as a guide.

13.3 IP67 DUST CAP Z-2

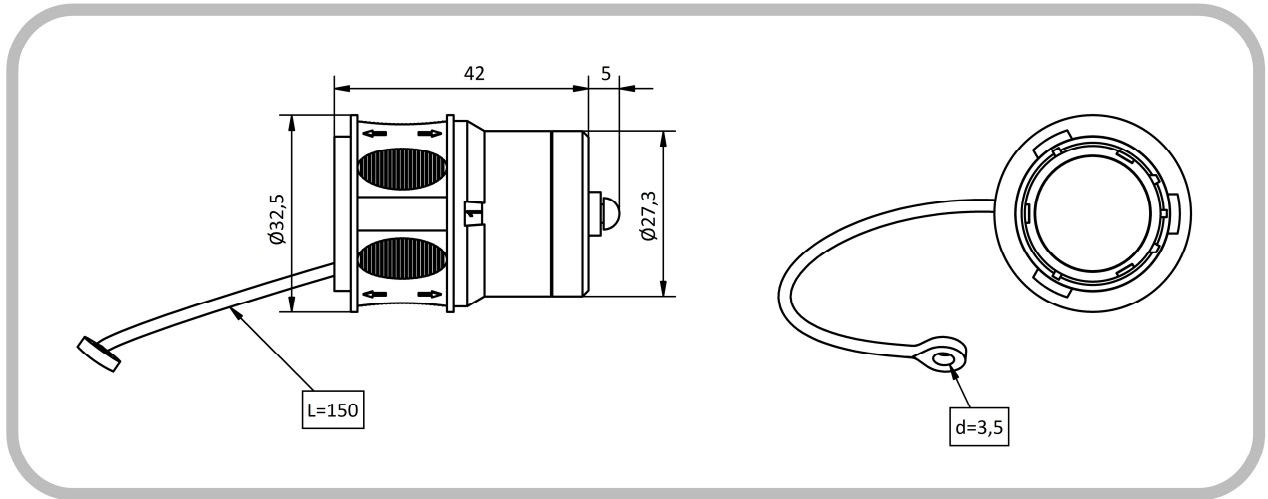

Z-2 dimensions, not mounted

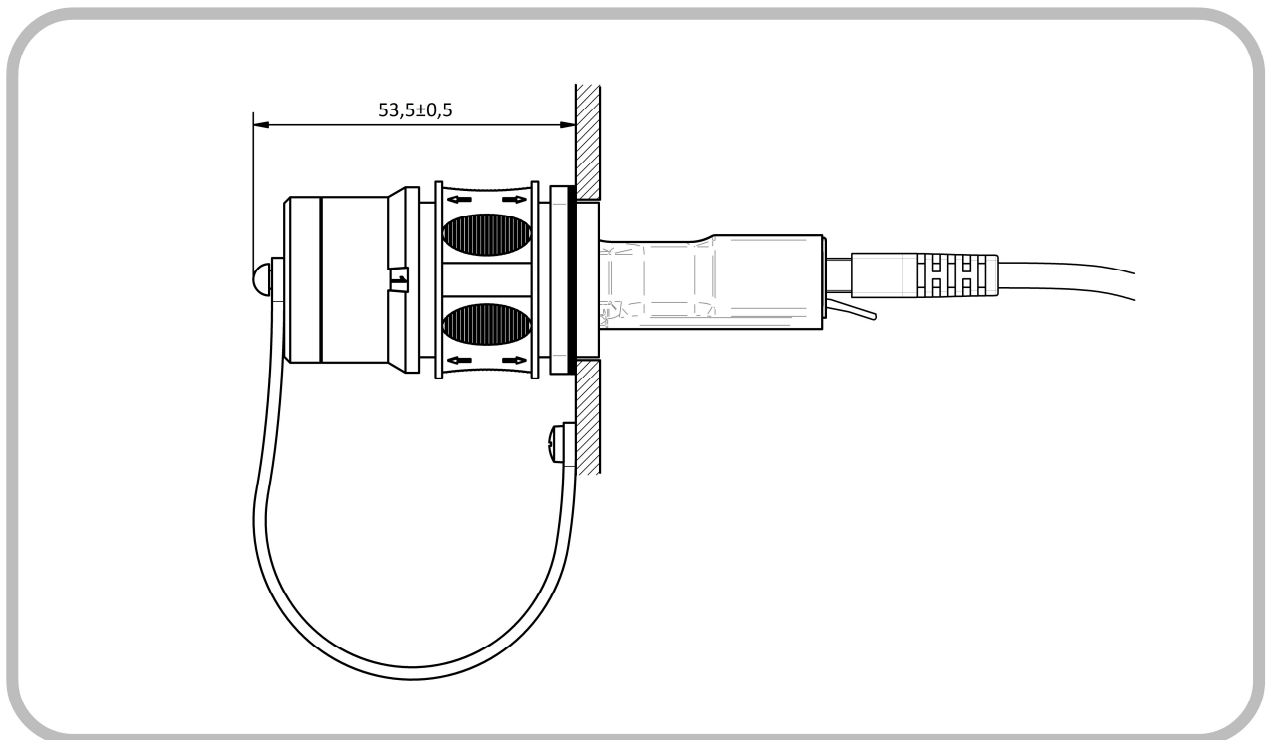

Assembly height of EN-10 with Z-2

14 QUALITY

EMO Systems GmbH maintains a certified quality management system for development and production in accordance with ISO 9001 and ISO 13485. Every network isolator is subjected to extensive quality control before delivery. Among other things, it is checked whether the achieved values for leakage current, dielectric strength, insertion loss, return loss and near crosstalk (NEXT) correspond to the specifications.

You will also find a declaration of conformity on our website confirming that the EMOSAFE network isolators comply with the requirements of the Low Voltage Directive (2014/35/EU), the Electromagnetic Compatibility Directive (2014/30/EU) and the Restriction of Use Directive hazardous substances in electrical and electronic equipment (2011/65/EU, RoHS).

15 PACKAGING

The packaging label provides the following information:

- Article description
- Quantity
- Date of manufacture
- Ordering code (OC)
- Serial number as 1D- (Code 128) and a 2D barcode (Data Matrix)

Contents:

- A network isolator of type EN-10H, EN-10HG, EN-10V or EN-10VG
- This data sheet

16 ENVIRONMENTAL PROTECTION INFORMATION

This device contains electronic components.

It must be returned to the manufacturer for disposal after use.

17 CONTACT AND SUPPORT

You can find the current contact details on our website: <https://emosystems.de/en/contact/>

OR YOU CAN REACH US BY EMAIL AT THE FOLLOWING ADDRESS: SUPPORT@EMOSYSTEMS.DE

18 LEGAL NOTICE

The information in this data sheet has been compiled to the best of our knowledge and with all care. However, we cannot guarantee that they are complete and error-free.

The user is responsible and liable for the correct use of this product. Neither EMO Systems GmbH nor EMO Systems Inc. assume liability.

This data sheet is subject to change without prior notice.